

## AN OPTIMIZED LOW-VOLTAGE LOW-POWER DOUBLE TAIL COMPARATOR FOR HIGH-SPEED ADCS

<sup>1</sup>P. Rajesh, <sup>2</sup>M. Priyanka, <sup>3</sup>P. Nalini, <sup>4</sup>M. Chandra Mouli

<sup>1</sup>Assistant Professor, <sup>2,3,4</sup>B.Tech Student

ECE Department, Raghu Engineering College, Visakhapatnam, India

### ABSTRACT

*As today's world has become smart i.e., digitalization has been spreading rapidly, the need for ultra low-power, area efficient and high-speed analog-to-digital converters is pushing towards the use of dynamic regenerative comparator to maximise the speed and power efficiency. In this paper, a dynamic double tail comparator with positive feed-back for latch regeneration has been designed with high-speed and low-offset. Simulations are carried out in 180nm and 90 nm CMOS technology. In the resultant comparator power dissipation and delay are reduced.*

**KEYWORDS:** Digitalization, Dynamic, Double Tail, Latch Regeneration, Offset

### I. INTRODUCTION

In modern life, electronic equipment is frequently used in all fields such as communication, transportation, entertainment, medical, household etc. The requirement of analog to digital converters is increasing day by day as they play a major role in converting the analog signals to digital ones. ADCs act as interface between the natural analog world and the real time digital world. Comparator is the fundamental block which acts as heart of the ADC. In general, a comparator is defined as an electronic device which compares the given analog input signal with reference voltage and produces a digital output i.e., either logic '0' or logic '1'. If the input to the non-inverting input is greater than that to the inverting input, the output is a logical 1. If the input to the non-inverting input is less than that to the inverting input, the output is a logical 0.

In this paper, Open loop comparators, pre-amplifier based comparators and dynamic comparators are discussed and a dynamic comparator is proposed to overcome the disadvantages of the previous topologies. The open loop comparator does not possess a clock input, due to which the output is generated randomly without a particular timing. On the other hand pre-amplifier based comparators make use of clock and achieve less offset voltage but suffer from static power dissipation and stacking [1]. This proposed dynamic comparator operated with low-voltage because of less stacking and achieves low-offset, high speed, low-power dissipation and high operating performance [1],[5].

This paper is organized as follows. Section II provides an overview of the various comparator topologies in terms of their advantages and drawbacks, and section III describes the analysis of proposed dynamic latched comparator. Section IV provides schematics of conventional and proposed dynamic latched comparators which are drawn in S-Edit. Simulation results obtained from HSPICE using 180nm and 90nm PTM technology [7] and their comparisons are presented in Section V and conclusion is drawn in Section VI.

### II. COMPARATOR ARCHITECTURE AND TOPOLOGIES

Architectures of voltage comparators will be classified into three types: Open-loop Comparators (op-amps without compensation), Pre-amplifier Based Latched Comparators (open-loop comparator

combined with dynamic regenerative latch), and Fully Dynamic Latched Comparator. The following Figure 1 illustrates the various blocks involved in the dynamic latched comparator.

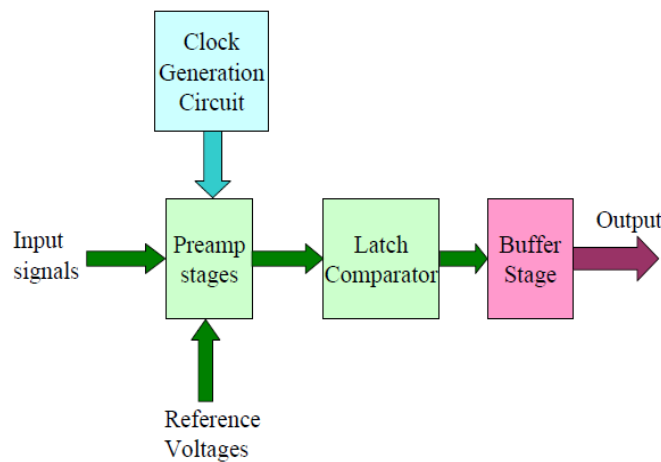

Fig. 1: High Speed Comparator Architecture

Open-loop, continuous time comparator, shown in Figure 2, is an operational amplifier without frequency compensation to obtain the largest possible bandwidth, hence improving its time response. Since the precise gain and linearity are of no interest in comparator design, no-compensation does not pose a problem. However, due to its limited gain-bandwidth product, open-loop comparators are too slow for many applications.

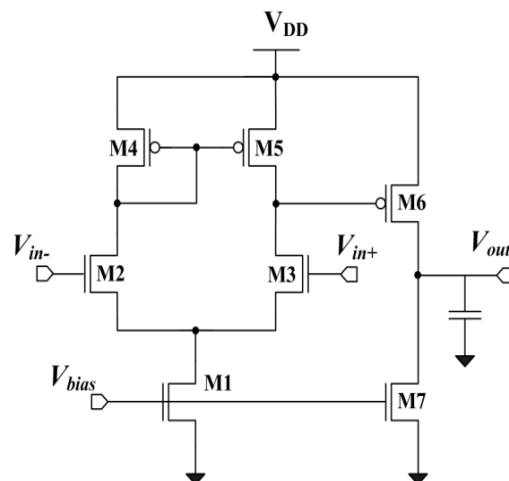

Fig. 2: Open-Loop Comparator

On the other hand, a cascade of open-loop amplifiers usually has a significantly larger gain-bandwidth product than a single-stage amplifier with the same gain. However, since it costs more area and power consumption [1], cascading does not give practical advantages for many applications. More practically, the input-referred latch offset voltage can be reduced by using the pre-amplifier preceding the regenerative output-latch stage [9] as shown in Figure 1. Pre-amplifier based latched comparator is a combination of a pre-amplifier and a latch. It can amplify a small input voltage difference to a large enough voltage to overcome the latch offset voltage and also can reduce the kickback noise [6]. However, the pre-amplifier based comparators suffer not only from large static power consumption for a large bandwidth.

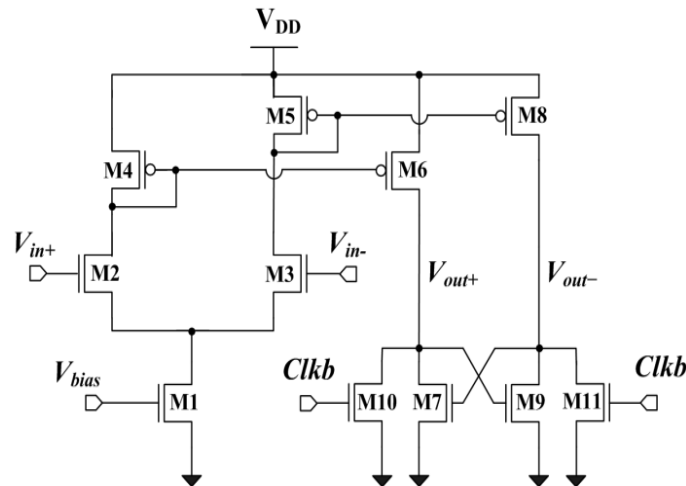

Fig. 3: Pre-Amplifier Based Latched Comparator

## 2.1 Conventional dynamic comparator

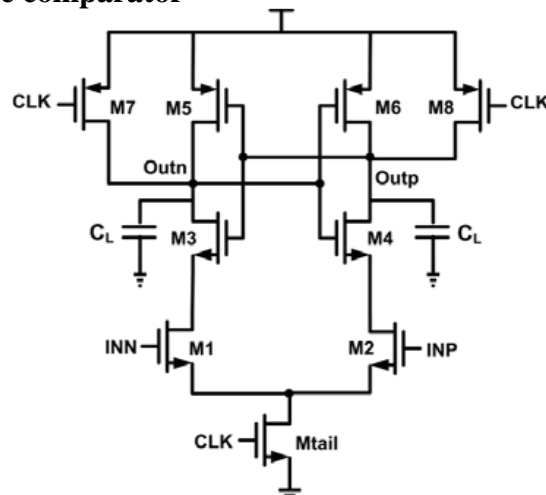

Fig. 4: Conventional Dynamic Comparator (Comparator 1)

The schematic diagram of the conventional dynamic comparator widely used in A/D converters, with high input impedance, rail-to-rail output swing, and no static power consumption [1],[5] is shown in Fig. 3. The operation of the comparator is as follows. During the reset phase when  $CLK = 0$  and  $M_{tail}$  is off, reset transistors ( $M7-M8$ ) pull both output nodes  $Outn$  and  $Outp$  to  $V_{DD}$  to define a start condition and to have a valid logical level during reset. In the comparison phase, when  $CLK = V_{DD}$ , transistors  $M7$  and  $M8$  are off, and  $M_{tail}$  is on. Output voltages ( $Outp$ ,  $Outn$ ), which had been pre-charged to  $V_{DD}$ , start to discharge with different discharging rates depending on the corresponding input voltage ( $INN/INP$ ). Assuming the case where  $V_{INP} > V_{INN}$ ,  $Outp$  discharges faster than  $Outn$ , hence when  $Outp$  (discharged by transistor  $M2$  drain current), falls down to  $V_{DD} - |V_{thp}|$  before  $Outn$  (discharged by transistor  $M1$  drain current), the corresponding pMOS transistor ( $M5$ ) will turn on initiating the latch regeneration caused by back-to-back inverters ( $M3, M5$  and  $M4, M6$ ). Thus,  $Outn$  pulls to  $V_{DD}$  and  $Outp$  discharges to ground. If  $V_{INP} < V_{INN}$ , the circuits works vice versa.

### Pros:

- The circuit has fast decision making capability i.e., the switching speed is high.
- Strong positive feedback is provided.

### Cons:

- Kick-back noise is produced.
- The circuit requires high input impedance.

### III. PROPOSED DUAL TAIL DYNAMIC COMPARATOR

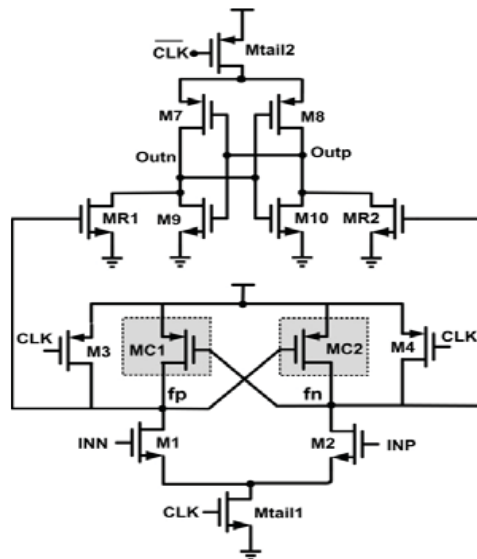

Fig. 5(a): Basic idea of the Proposed Comparator (Comparator 2)

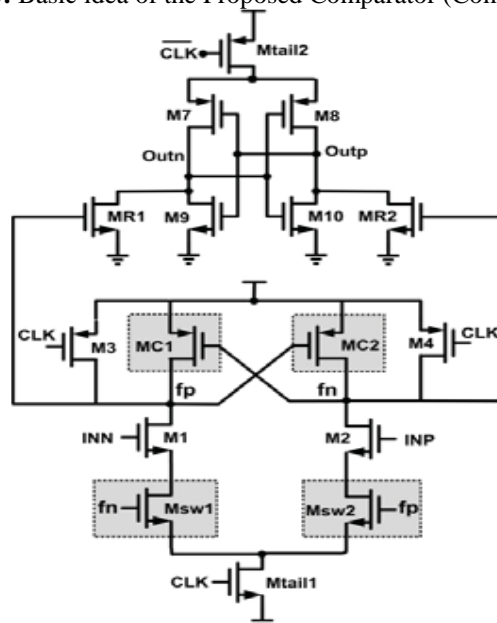

Fig. 5(b): Final Structure of the Proposed Comparator (Comparator 3)

Due to the better performance of double-tail architecture in low-voltage applications [2], the proposed comparator is designed based on the double-tail structure. The main idea of the proposed comparator is to increase  $V_{fn}/fp$  in order to increase the latch regeneration speed [4]. For this purpose, two control transistors (Mc1 and Mc2) have been added to the first stage in parallel to M3/M4 transistors but in a cross-coupled manner.

The operation of the proposed comparator is as follows:

During reset phase ( $CLK = 0$ , Mtail1 and Mtail2 are off, avoiding static power), M3 and M4 pulls both fn and fp nodes to VDD, hence transistor Mc1 and Mc2 are cut off. Intermediate stage transistors, MR1 and MR2, reset both latch outputs to ground.

During decision-making phase ( $CLK = VDD$ , Mtail1, and Mtail2 are on), transistors M3 and M4 turn off. Furthermore, at the beginning of this phase, the control transistors are still off (since fn and fp are about VDD). Thus, fn and fp start to drop with different rates according to the input voltages. Suppose  $V_{INP} > V_{INN}$ , thus fn drops faster than fp, (since M2 provides more current than M1). As long as fn continues falling, the corresponding pMOS control transistor (Mc1 in this case) starts to turn on, pulling fp node back to the VDD; so another control transistor (Mc2) remains off, allowing fn to be

discharged completely. In other words, unlike conventional double-tail dynamic comparator, in which  $V_{fn}/V_{fp}$  is just a function of input transistor transconductance and input voltage difference in the proposed structure as soon as the comparator detects that for instance node  $fn$  discharges faster, a pMOS transistor ( $M_{c1}$ ) turns on, pulling the other node  $fp$  back to the VDD. Therefore by the time passing, the difference between  $fn$  and  $fp$  ( $V_{fn}/V_{fp}$ ) increases in an exponential manner, leading to the reduction of latch regeneration time. Despite the effectiveness of the proposed idea, one of the points which should be considered is that in this circuit, when one of the control transistors (e.g.,  $M_{c1}$ ) turns on, a current from VDD is drawn to the ground via input and tail transistor (e.g.,  $M_{c1}$ ,  $M_1$ , and  $M_{tail1}$ ), resulting in static power consumption. To overcome this issue, two nMOS switches are used below the input transistors [ $M_{sw1}$  and  $M_{sw2}$ ].

At the beginning of the decision making phase, due to the fact that both  $fn$  and  $fp$  nodes have been pre-charged to VDD (during the reset phase), both switches are closed and  $fn$  and  $fp$  start to drop with different discharging rates. As soon as the comparator detects that one of the  $fn/fp$  nodes is discharging faster, control transistors will act in a way to increase their voltage difference. Suppose that  $fp$  is pulling up to the VDD and  $fn$  should be discharged completely, hence the switch in the charging path of  $fp$  will be opened (in order to prevent any current drawn from VDD) but the other switch connected to  $fn$  will be closed to allow the complete discharge of  $fn$  node. In other words, the operation of the control transistors with the switches emulates the operation of the latch.

### Pros and Cons:

- In, the main idea of the proposed comparator control transistors are used which results in the increase of latch regeneration speed. But there is an increase in the number of transistors as well as the power dissipation of the circuit is high.
- In the final structure, even though the numbers of transistors are more, power dissipation & delay of the circuit is reduced and the circuit operates with high speed.

## IV. SCHEMATICS AND SIMULATED WAVEFORMS

### 3.1 Schematics:

All the comparators schematics are drawn in S-Edit of Tanner Tools and from which netlists are extracted, which are given as input files for the H-Spice. Simulations are carried out in H-Spice and waveforms are generated using Avanwaves.

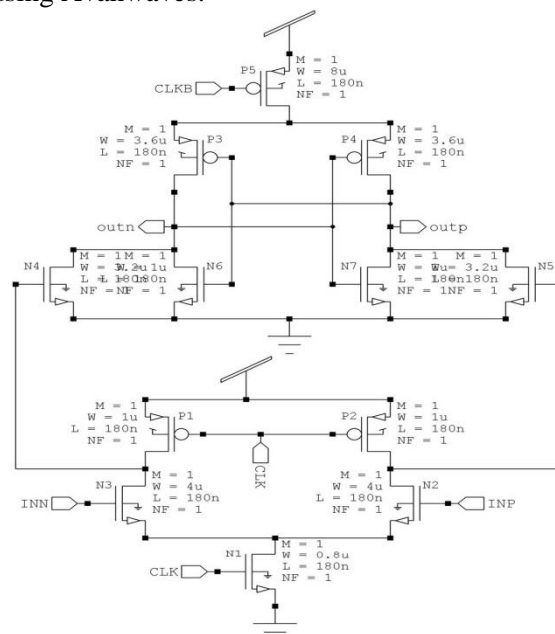

Fig. 6: Schematic of Conventional Dynamic Comparator (Comparator1)



3.2 Simulated Waveforms:

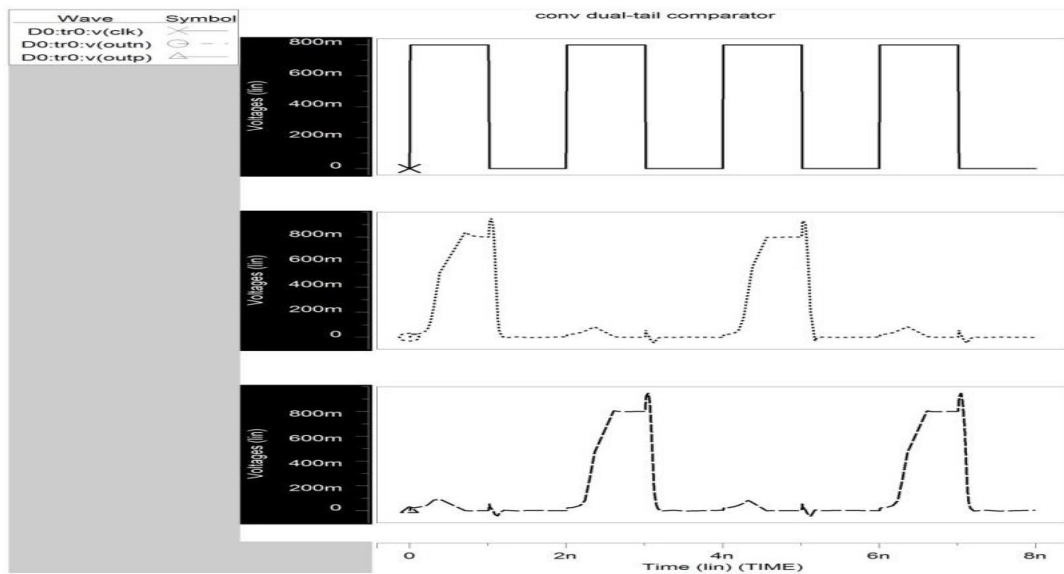

Fig. 9: Simulated Waveform of Comparator 1 (180nm)

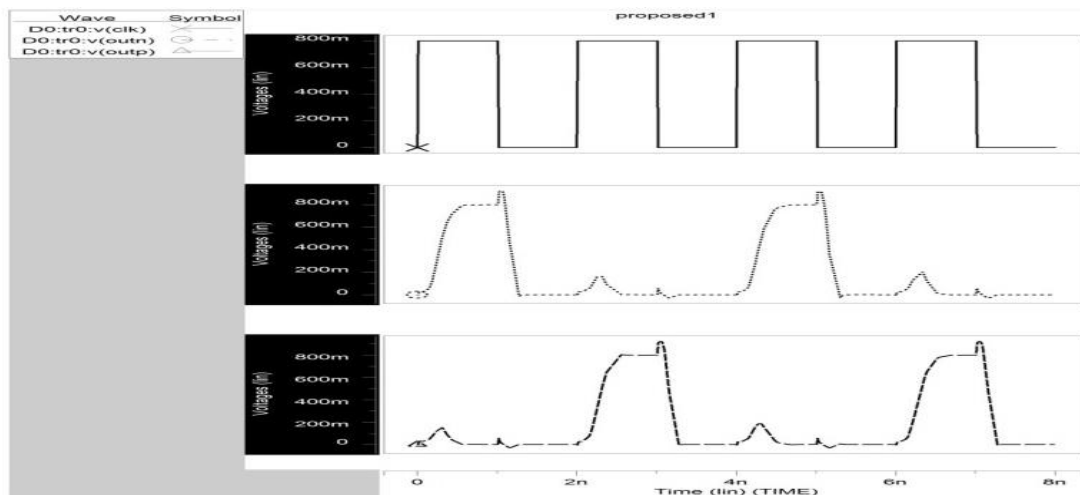

Fig. 10: Simulated Waveform of Comparator 2 (180nm)

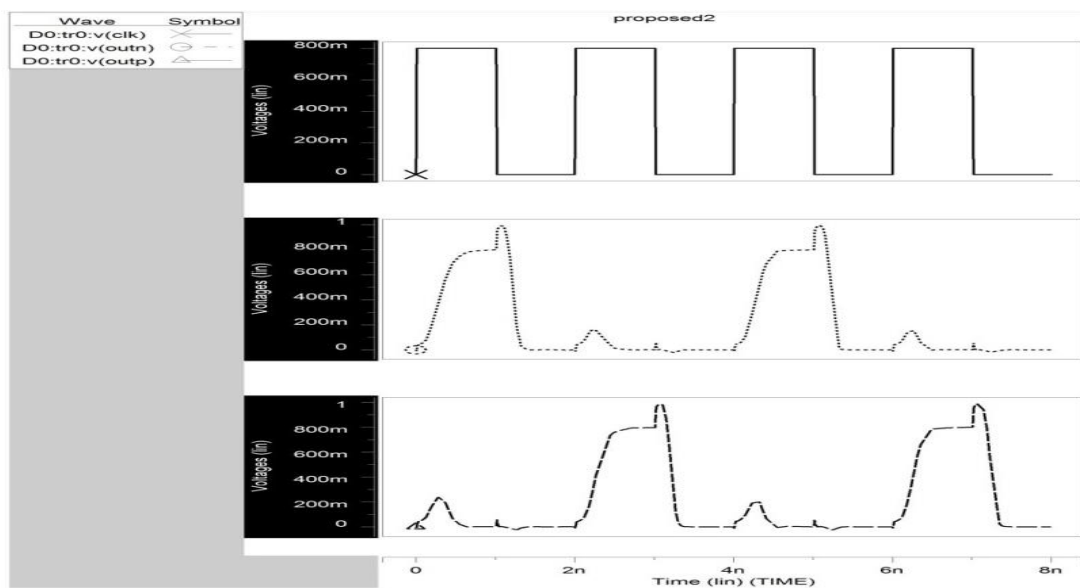

Fig. 11: Simulated Waveform of Comparator 3 (180nm)

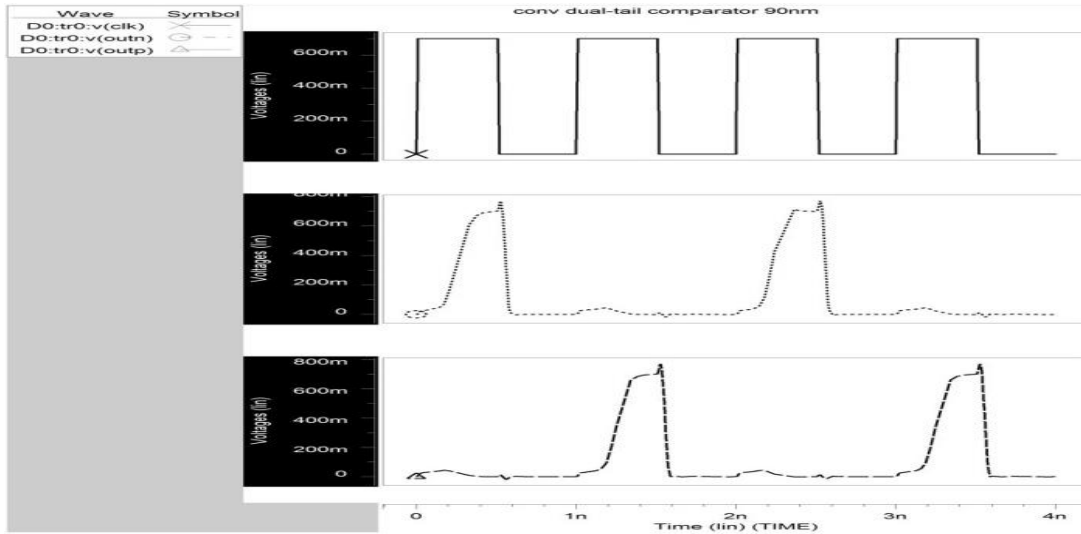

Fig. 12: Simulated Waveform of Comparator 1 (90nm)

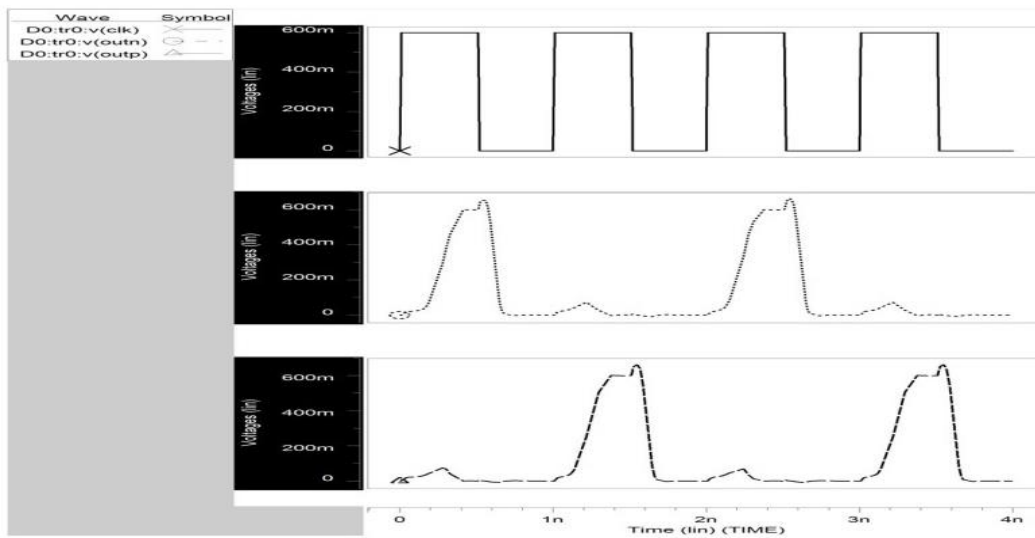

Fig. 13: Simulated Waveform of Comparator 2 (90nm)

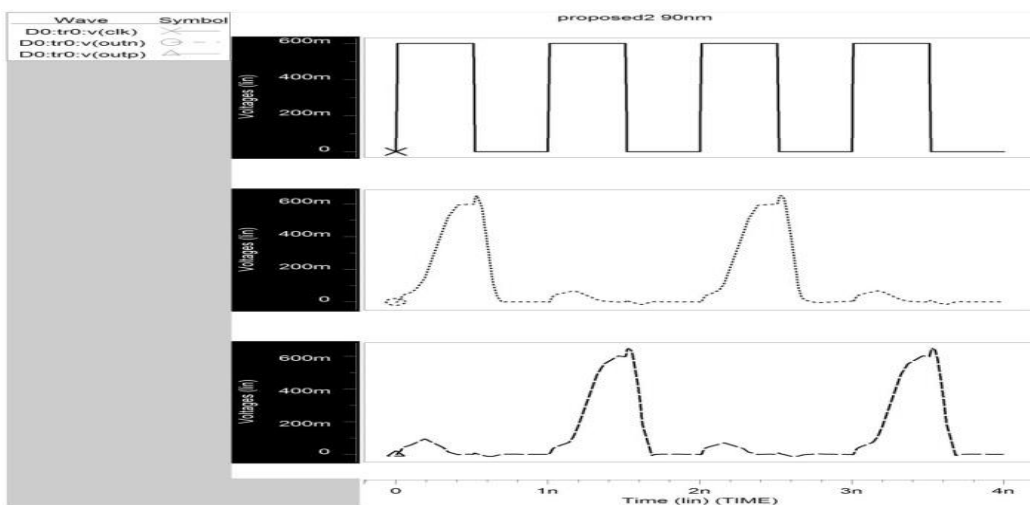

Fig. 14: Simulated Waveform of Comparator 3 (90nm)



## V. PERFORMANCE COMPARISON

To compare the performances of the proposed comparator with the previous works, each circuit was designed using 180nm and 90nm technologies with  $V_{DD(max)} = 1.2$ ,  $V_{DD(min)} = 1.2$ ,  $f_{CLK(max)} = 1\text{GHz}$ ,  $f_{CLK(min)} = 500\text{MHz}$ ,  $C_{LOAD} = 7\text{fF}$ ,  $Temp = 25^\circ\text{C}$ , and common mode voltage  $V_{com(max)} = 0.7\text{V}$ ,  $V_{com(min)} = 0.4\text{V}$ ,  $\Delta V_{in} = 10\text{mV}$  and simulated with HSPICE.

Table 1 illustrates the performance parameters of dynamic comparators in 180nm and 90nm Technologies.

**Table 1:** Delay and Power comparison (180nm and 90nm Technologies)

Type	180nm		90nm	
	Power ( $\mu\text{w}$ )	Delay (ps)	Power ( $\mu\text{w}$ )	Delay (ps)
Comparator1	62.3	330	48.8	247
Comparator2	37.1	273	30	222
Comparator3	35.6	272	24.3	232

The power consumption (in  $\mu\text{w}$ ) comparison of dynamic comparator designs are shown in figure 15 in 180nm and 90nm technologies.

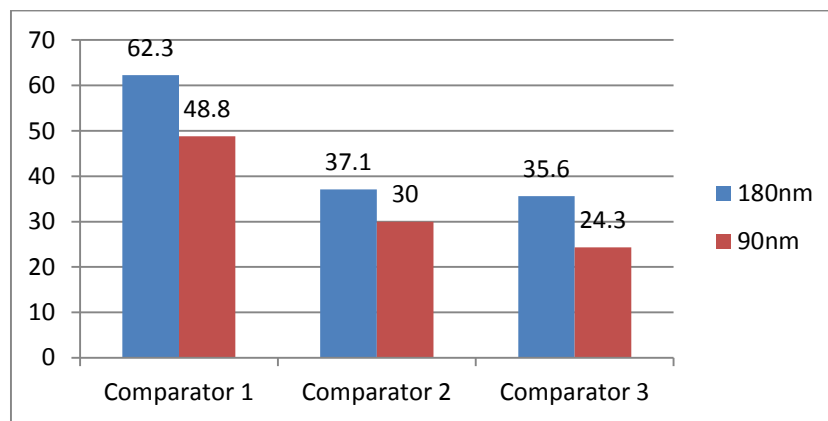

**Fig. 15:** Power consumption comparison of dynamic comparators

The delay (in ps) comparison of dynamic comparator designs are shown in figure 16 in 180nm and 90nm technologies.

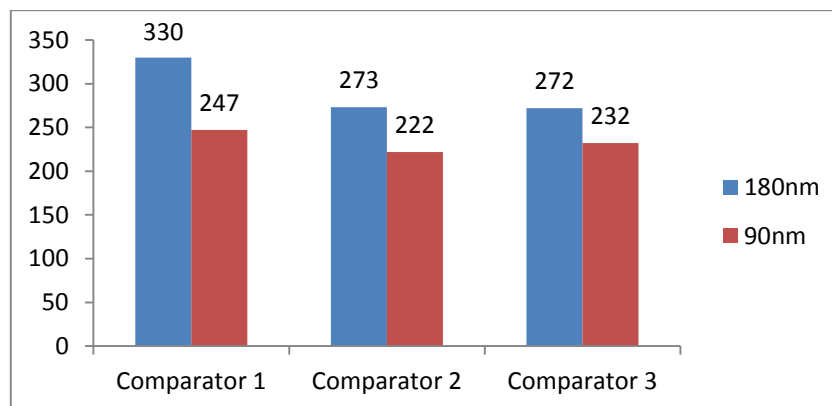

**Fig. 16:** Delay comparison of dynamic comparators

## VI. CONCLUSION

In this paper, the comparator circuits for high-speed ADCs have been presented. The conventional dynamic and conventional double tail comparators have been simulated with 180nm and 90nm CMOS technology using H-Spice and their performance parameters such as power and delay are compared. The proposed dynamic comparator (Comparator 3) shows minimal power consumption of 35.6  $\mu$ W and 24.3  $\mu$ W, minimal propagation time delay of 272 ps and 232 ps in 180nm and 90nm respectively. The proposed comparator is best suitable for low power high-speed ADCs.

## REFERENCES:

- [1]. B. Wicht, T. Nirschl, and D. Schmitt-Landsiedel, "Yield and speed optimization of a latch-type voltage sense amplifier," *IEEE J. Solid-State Circuits*, vol. 39, pp. 1148-1158, July 2004.
- [2]. D. Schinkel, E. Mensink, E. Kiumperink, E. van Tuijl and B. Nauta, "A Double-Tail Latch-Type Voltage Sense Amplifier with 18ps Setup+Hold Time," *ISSCC Dig. Tech. Papers*, pp. 314-315 and 605, Feb. 2007.
- [3]. M. Miyahara, Y. Asada, P. Daehwa and A. Matsuzawa, "A Low-Noise Self-Calibrating Dynamic Comparator for High-Speed ADCs," in *Proc. A-SSCC*, pp. 269-272, Nov. 2008.
- [4]. A. Nikoozadeh and B. Murmann, "An Analysis of Latch Comparator Offset Due to Load Capacitor Mismatch," *IEEE Trans. Circuits Syst. II: Exp. Briefs*, vol. 53, no. 12, pp. 1398-1402, Dec. 2006 Philip E. Allen and Douglas R. Holberg, *CMOS Analog Circuit Design*, 2nd ed. New York, NY: Oxford, 2002.
- [5]. S. Kale and R. S. Gamad, "Design of a CMOS Comparator for Low Power and High Speed," *International Journal of Electronic Engineering Research*, vol. 2, no. 1, pp. 29-34, 2010
- [6]. Pedro M.Figueiredo, Joao C.Vital, "Kickback Noise Reduction Techniques for CMOS Latched Comparator", *IEEE Transactions on Circuits and Systems*, vol.53, no.7, pp.541- 545, July 2006.
- [7]. 90nm Predictive Technology Model (PTM), [Online]Available:<http://www.eas.asu.edu/~ptm/latest.htm>
- [8]. Sumanen, M. Waltari, V. Hakkarainen, K. Halonen, "CMOS Dynamic Comparators for Pipeline A/D Converters," *IEEE ISCAS*, vol. 5, pp. 157 - 160, May 2002.
- [9]. Jeon, Heung Jun, "Low-power high-speed low-offset fully dynamic CMOS latched comparator" (2010).
- [10]. Philip E. Allen and Douglas R. Holberg, *CMOS Analog Circuit Design*, 2nd Ed. New York, NY: Oxford, 2002.
- [11]. D. N. Kapadia and P. P. Gandhi, "Implementation of CMOS charge sharing dynamic latch comparator in 130 nm and 90 nm technologies," in *Proceedings of the IEEE Conference on Information and Communication Technologies (ICT '13)*, pp. 16–20, JeJu Island, Republic of Korea, April 2013.
- [12]. Samaneh Babayan-Mashhadi, Student Member, IEEE, and Reza Lotfi, Member, IEEE, "Analysis and Design of a Low-Voltage Low-Power Double-Tail Comparator", *IEEE Transactions on Very Large Scale Integration (VLSI) Systems*, Vol. 22, No. 2, February 2014.

## AUTHORS

**P. Rajesh** received his B.Tech degree from Raghu Engineering College in the year 2011 and received M.Tech degree from MVGR College of Engineering in the year 2013. He is working as an Assistant Professor in the Department of Electronics and Communication Engineering at Raghu Engineering College. He has published four Papers in International Journals. His research activities are related to Low power VLSI Design.



**M. Priyanka** presently pursuing his B.Tech in Electronics and Communication Engineering, Raghu Engineering College.



**P. Nalini** presently pursuing his B.Tech in Electronics and Communication Engineering, Raghu Engineering College.



**M. Chandra Mouli** presently pursuing his B.Tech in Electronics and Communication Engineering, Raghu Engineering College.

