

QUATERNARY DIVISION OPERATION BASED ON ALL-TERAHERTZ OPTICAL ASYMMETRIC DEMULTIPLEXER (TOAD)

Alaa A. Al-Saffar and Doaa A. Karim

Foundation of Technical Education, Basrah Technical College, Basrah City, Iraq
Department of Electrical Engineering, Basrah University, Basrah City, Iraq

ABSTRACT

Quaternary division based on all Terahertz Optical Asymmetric Demultiplexer (TOAD) is proposed. It shows quaternary division operation based on discrete-detect zero circuit using T-gate. In this present work all optical scheme of the different quaternary logical states are represented by different polarized state of light. Introducing the discrete-detect zero circuit reduces the overall number of the T-gates in the division operation and the number of T-gate incoming data transmission lines to three. The design promises both higher processing speed and accuracy. The design can be evolution for more complex optical circuits of enhanced functionality in which the T-gate is the basic building block. The principles and possibilities of design of all-optical quaternary division circuits are proposed and described through numerical simulation.

KEYWORDS: SOA, TOAD, QMIN, T-GATE, Quaternary arithmetic

I. INTRODUCTION

The field of computation and signal processing is growing day by day. In last three to four decades, the philosophy, science and technical prospects enriched the scientific communities a lot. Massive parallelism, speed of operation, increased spatial density attracts in many ways the scientists, researchers and technologists [1, 2]. In order to overcome the electronic bottlenecks and fully exploit the advantages of optics, it is necessary to move towards networks, where the transmitted data will remain exclusively in all optical domains without optical electrical optical (OEO) conversions.

The dream of photonics is to have a completely all-optical technology [3]. In high-speed data processing, photonics plays a significant role in optical computing in future into which optical communication can be possible in the range of terahertz [4].

All optical logic operations have many potential applications in optical communication and computing systems. Various architectures, algorithms, logical and logic operations have been proposed in the field of optical/optoelectronic computing and parallel signal processing in last few decades [5]. Gayen et al. proposed all optical reconfigurable logic operations with the help of terahertz optical asymmetric demultiplexer (TOAD) is proposed and described. The paper describes the all-optical reconfigurable logic operations using a set of all-optical multiplexer and optical switches. It exploits the advantages of TOAD-based switch to design an integrated all-optical circuit which can perform the different logic operations AND, XOR, NOR and NOT [6]. Chattopadhyay et al. proposed a novel scheme for an all-optical clocked D flip-flop, with very low complexity. This new flip-flop configuration is based on a semiconductor optical amplifier — Mach-Zehnder interferometer (SOA-MZI), with a feedback loop, and presents two stable states determined by the phase shift between the two MZI arms [7]. Chattopadhyay and Roy proposed all optical scheme of polarization encoded quaternary (4-valued) MAX logic gate with the help of Terahertz Optical Asymmetric Demultiplexer (TOAD) based fiber

interferometric switch is described. For the quaternary information processing in optics, the quaternary number (0, 1, 2, and 3) can be represented by four discrete polarized states of light [8]. Moniem and Tanay proposed the implementation of binary decoder and encoder and using the optical hardware components. All-optical circuits are implemented and designed with nonlinear material such as terahertz optical asymmetric demultiplexer (TOAD) in optical tree architecture, polarization converters, and optical circulator [9].

Among the proposed schemes, the terahertz optical asymmetric demultiplexer (TOAD) / semiconductor optical amplifier (SOA)-assisted Sagnac gate effectively combines fast switching time and a reasonable noise figure, with the ease of integration and overall practicality that enables it to compete favorably with other similar optical time division multiplexing (OTDM) devices. TOAD is characterized by the attractive features of fast switching time, high repetition rate, low power consumption, low latency, noise and jitter tolerance, compactness, thermal stability and high nonlinear properties, which enable their efficient exploitation in a real ultra-high speed optical communications environment [10]. TOAD have the potential of being integrated, which in turn means that they can be repeatable and reliably manufactured and massively produced so that they can be of commercial value and favorably compete with other buffering solutions [11]. TOAD is operationally versatile, i.e. they can be exploited in more complex all-optical signal processing applications without significantly changing their fundamental architecture. In this communication we propose the TOAD-based switch to design an integrated all-optical circuit which can perform different logical operations.

In this paper the quaternary division structure with detection circuit of zero number has been presented. The structure of quaternary division based on (TOAD) used to design T-gate. Minimum number of T-gates is used to set the design. The paper is organized as follows. In Section II principle and operation of TOAD based optical switch is discussed. Section 3.1 and section 3.2 describe the design and operational principle of some basic all-optical quaternary logic circuits (QMIN, Delta Literal). Section 3.3 describes the principle of T-gate and its operation. Section IV discuss detect-zero circuit and its operational principle. Section V describes quaternary division operation with discrete detect zero circuit. Section VI discusses simulation results and discussion. Section VII discusses conclusion and suggests a roadmap for future works.

II. SOA-ASSISTED SAGANAC SWITCH/TOAD BASED ALL-OPTICAL SWITCH

Quaternary logic ($R=4$) has four logical states {0, 1, 2, 3}. In optics, the quaternary number has been represented by four discrete polarized state of light. In optical implementation we can consider the set of quaternary logic states {0, 1, 2, 3}:

- 0 = no light,
- 1 = vertically polarized light (\uparrow),
- 2 = horizontally polarized light (\bullet) and
- 3 = partially polarized light (\odot).

Like binary world there are also numbers of basic gates in multi-valued logic world. Depending on the radix and number of variables used, different logic functions can be generated. The numbers of possible functions are [12].

$$f(R, n) = R^{(R)^n} \quad (1)$$

Where R is the radix and n is the number of variables, in quaternary logic ($R=4$) of two variables ($n=2$), there are $f(4, 2) = 4^{4^2} = 4294967296$ possible functions. Among the proposed schemes, TOAD / SOA-assisted Sagnac gate effectively combines fast switching time and a reasonable noise figure, with the ease of integration and overall practicality that enables it to compete favorably with other similar optical time division multiplexing (OTDM) devices [13].

TOAD are characterized by the attractive features of fast switching time, high repetition rate, low power consumption, low latency, noise and jitter tolerance, compactness, thermal stability and high nonlinear properties, which enable their efficient exploitation in a real ultra-high speed optical communications environment. TOAD have the potential of being integrated, which in turn means that they can be repeatable and reliable manufactured and massively produced so that they can be of

commercial value and favorably compete with other buffering solutions. TOAD based switch shown in Fig. 1, which can operate at frequencies in terahertz range. It uses a SOA that is asymmetrically positioned in the fiber loop. The loop contains a control pulse (CP) of other polarized light than the input pulse (IP) and a SOA that is offset from the loop's midpoint by a distance Δx as shown in Fig. 1(a). [14]. The switch is essentially a fiber loop jointed at the base by an optical 50:50 coupler, which splits the IP into two equal parts clockwise (cw) and anticlockwise (ccw) that counter propagate around the loop and recombine at the coupler. Another strong light pulse is also injected to the loop is CP. Note that the IP and CP are orthogonal. A filter (F) may be used at the output to reject the control and pass the input pulse. In almost all TOAD discussed by many authors, the transmitting mode of the device (output port) is used to take the output signal. But the signal that exits from the input port (reflecting mode) remains unused. In this present communication, the output have taken from the transmitting mode and of reflecting mode of the device.

The output power at Transmitted port (T-port) and Reflected port (R-port) can be expressed as [15] :

$$P_T(t) = \frac{P_{in}(t)}{4} \cdot \{G_{cw}(t) + G_{ccw}(t) - 2\sqrt{G_{cw}(t) + G_{ccw}(t)} \cos(\Delta\Phi)\} \tag{2}$$

$$P_R(t) = \frac{P_{in}(t)}{4} \cdot \{G_{cw}(t) + G_{ccw}(t) + 2\sqrt{G_{cw}(t) + G_{ccw}(t)} \cos(\Delta\Phi)\} \tag{3}$$

Where, $G_{cw}(t), G_{ccw}(t)$ are the power gain and the phase difference between cw and ccw pulse [16], $\Delta\Phi = -\alpha/2 \ln(G_{cw}/G_{ccw})$, α is line-width enhancement factor. In the absence of a control signal, IP enters the fiber loop, pass through the SOA at different times as they counter-propagate around the loop, and experience the same unsaturated amplifier gain G_0 of SOA, recombine at the input coupler i.e. $G_{ccw} = G_{cw}$, Then, $\Delta\Phi = 0$. So expression for $P_T(t) = 0$ and $P_R(t) = P_{in}(t)G_0$. It shows that data is reflected back towards the source. When a control pulse is injected into the loop, it saturates the SOA and changes its index of refraction. As a result, cw and ccw will experience differential gain saturation profiles i.e. $G_{ccw} \neq G_{cw}$. Therefore, they recombine at the input coupler, and then $\Delta\Phi \approx -\pi$ the data will exit from the transmitted port i.e. $P_T(t) \neq 0$ and $P_R(t) \approx 0$, the corresponding values can be obtained from eq. (2) and eq. (3).

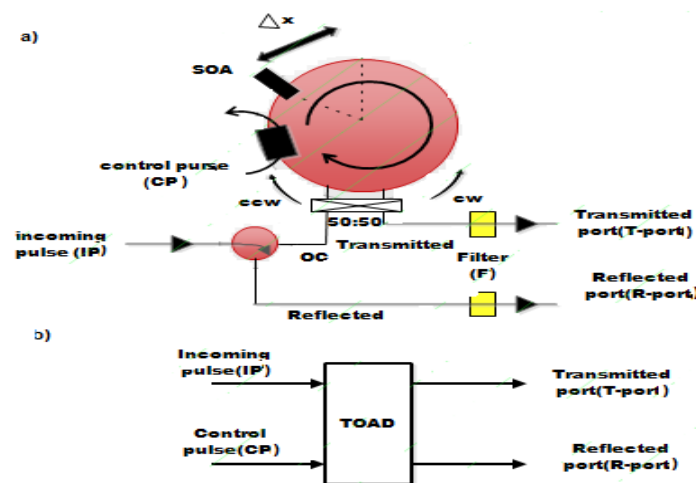

Figure 1. Terahertz optical asymmetric demultiplexer (TOAD) based switch. (a) Schematic diagram CP: control pulse, SOA: semiconductor optical amplifier, OC: optical circulator, which separates the reflected light from the loop to port and (b) block diagram [16].

The principle operation of TOAD can be described as:

Case1: CP=ON, then SOA changes its index of refraction. As a result, cw and ccw will experience a differential gain saturation profiles. Therefore, cross phase modulation (XPM) takes place when they recombine at the input coupler. Then, relative phase difference between cw and ccw pulses becomes π and the data will exit from the transmitted port (T-port) according to Fig. 1.

Case 2: CP=OFF, cw and ccw enter the fiber loop, pass through the SOA at different times counter-propagate around the loop, it experience the nearly same unsaturated amplifier gain of SOA, and then they recombine at the input coupler. Relative phase difference between cw and ccw is zero (0), and no data is found at the T-port. Then data is reflected back toward the source and isolated by optical circulator (OC) [17]. Table-1 describe the operation of TOAD.

Table 1. Truth table of TOAD operation

Incoming pulse(IP)	Control pulse(CP)	T-port	R-port
0	0	0	0
0	1	0	0
1	0	0	1
1	1	1	0

III. APPLICATIONS OF TERAHERTZ OPTICAL ASYMMETRIC DEMULTIPLEXER (TOAD)

3.1. Design of two inputs all-optical quaternary MIN (X, Y) circuit

The QMIN operation is shown in eq. (4), the operator \wedge is QMIN operation

$$x_1 \wedge x_2 \wedge \dots \wedge x_n = QMIN(x_1, x_2, \dots, x_n) \quad (4)$$

A QMIN(x, y) function is shown in table-2, and the optical circuit is shown in Fig. 2. Here light from inputs X and Y fall on two polarization beam splitter (PBS₁ and PBS₂), where it split into two polarized light one is vertically polarized (\updownarrow) and the other is horizontally polarized (\bullet). X₁, Y₁ are vertically polarized (\updownarrow), and X₂, Y₂ are horizontally polarized (\bullet). Light from X₂ and Y₂ are fed to two switches S₁ and S₂ as incoming signal, and also their control signals have taken from Y₂ and X₂, respectively. The lower outputs of S₁ and S₂ are passed through a polarization converter (pc) which is preferably half wave plate ;converts vertically polarized light to horizontal one and vice versa. It is indicated as S_{1L} and S_{2L}, respectively. Then, X₁ and S_{1L} are combined by a beam combiner BC-1, and the combined ray (C₁) is connected to another switch S₃ as incoming signal. Also, Y₁ and S_{2L} are combined by BC-2, and the combined ray (C₂) is connected to S₃ as control signal. The upper output channel of S₃ (S_{3U}) is fed to BC-3. Again X₂ and Y₂ are fed to another switch S₄ as incoming and the control signal ,respectively [18]. All the control signals are amplified by an erbium-doped fiber amplifier (EDFA) [19].When the incoming light signal is incident on the wavelength converter (WC), it converts the wavelength of the incoming signal to wavelength of the control signal. The upper output channel of this switch S₄ (S_{4U}) is connected to BC-3. The combined ray is the final output [18].

Table 2. Truth table of quaternary MIN(X, Y)

X \ Y	0(z)	1(\updownarrow)	2(\bullet)	3(\diamond)
0(z)	0	0	0	0
1(\updownarrow)	1	1	1	1
2(\bullet)	1	1	2	2
3(\diamond)	1	1	2	3

The operational principle of quaternary minimum is illustrated as:

CASE 1: $X=0, X_1=X_2=0$, if $Y=0; Y_1=Y_2=0$ then $S_{1L}=C_1=S_{2L}=C_2=S_{3U}=S_{4U}=O/P=0$. Therefore, for different values of $Y<123>$ the output is 0 (no light).

CASE 2: $X=1, X_1=1, X_2=0$, if $Y=0; Y_1=Y_2=0$ then, $C_1=1, S_{1L}=C_2=S_{2L}=S_{3U}=S_{4U}=O/P=0$. For different values of $Y<123>$, the output is 1 (vertical polarized light).

CASE 3: $X=2, X_1=0, X_2=2$, if $Y=0; Y_1=Y_2=0$ then, $S_{1L}=C_1=2, S_{2L}=C_2=S_{3U}=S_{4U}=O/P=0$. For values of $Y<23>$, the output is 2 (horizontal polarized light) but if the value of Y is 1 then, the output is 1 (vertical polarized light).

CASE 4: $X=3, X_1=1, X_2=2$, if $Y=0; Y_1=Y_2=0$ then, $S_{2L}=C_2=S_{3U}=S_{4U}=0, S_{1L}=2, C_1=3$ and the output is 0. For the different values of $Y <123>$ the output equals to the value of Y .

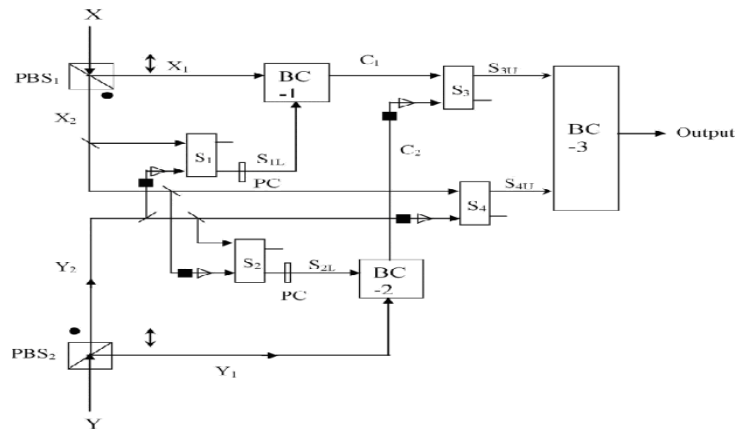

Figure 2. All-optical quaternary QMIN(X, Y) circuit. S: switch, NOLM: Non-linear optical loop mirror, PBS: polarizing beam Splitter, BC: beam Combiner, PC: polarization converter, ► EDFA: erbium doped fiber amplifier, ■ wavelength converter [18].

3.2. Design of all optical quaternary Delta Literal circuit

Literals are very important function in multi-valued logic based information processing. The truth table of Delta literal circuit is in the table- 4 and the circuit diagram is shown in the Fig. 3. Here, X is the quaternary input, which can take any one of the four quaternary logic states $<0123>$ and the outputs are x^0, x^1, x^2 and x^3 , respectively [4].

Table 3. Truth table of quaternary Delta Literals

X \ O/P	X^3	X^2	X^1	X^0
0 (z)	0	0	0	3
1 (↓)	0	0	3	0
2 (●)	0	3	0	0
3 (⬇)	3	0	0	0

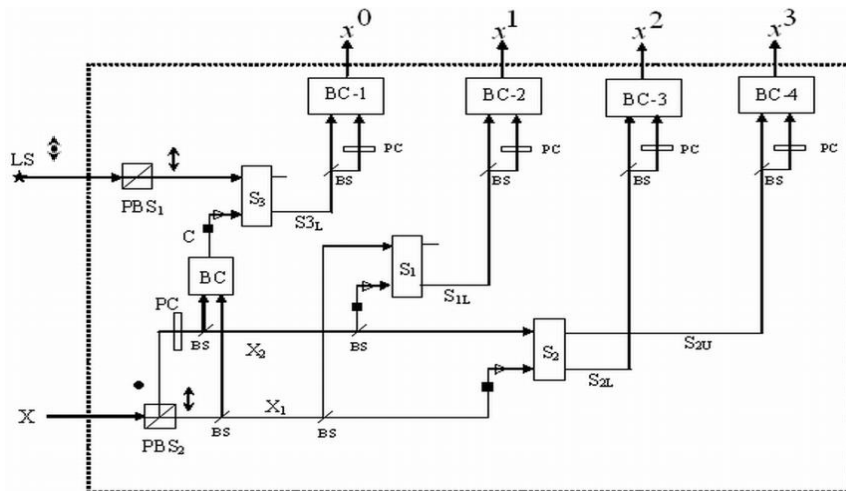

Figure 3. All optical quaternary delta literal circuit [18].

The operation of quaternary delta literals is briefly described in table 4.

Table 4. Truth table of operational principle of quaternary delta literal

X	X ₂	X ₁	S _{1L}	S _{2U}	S _{2L}	S _{3L}	X ³	X ²	X ¹	X ⁰
0 (z)	0	0	0	0	0	1	0	0	0	3
1 (↑)	0	1	1	0	0	0	0	0	3	0
2 (•)	1	0	0	0	1	0	0	3	0	0
3 (⋄)	1	1	0	1	0	0	3	0	0	0

3.3. Quaternary T-gate

This T-gate is successfully used for designing any quaternary circuits, so it is called ‘universal’ element of quaternary logic. The four incoming data transmission lines are ‘A’, ‘B’, ‘C’ and ‘D’ [which can be any one of the 4-logical states i.e. 0 (no light), 1(↑), 2(•), 3(⋄)] and ‘X’ is the selection input. By using proper value at the selection input one of the data (A, B, C or D) can be forwarded at the output [4].

The mathematical expression for all-optical quaternary T-gate using QMIN & delta literals can be written as [20]:

$$O=(A \wedge X^{<3000>} + B \wedge X^{<0300>} + C \wedge X^{<0030>} + D \wedge X^{<0003>}) \quad (5)$$

The schematic diagram for quaternary T-gate is shown in Fig. 4.

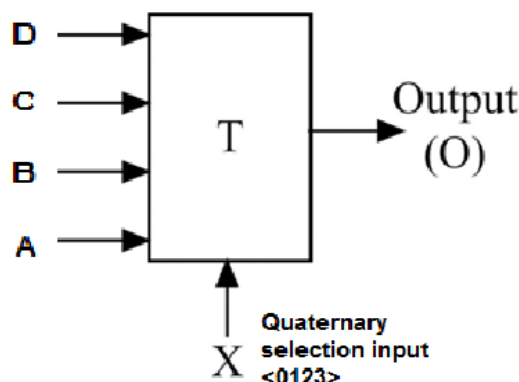

Figure 4. All optical Quaternary T-gate.

Where, $x \wedge y = \text{minimum of } (x, y)$ and ζ - literals function is $X^a = (R - 1)$ if $x=a$, else 0.

IV. PROPOSED DISCRETE DETECT-ZERO CIRCUIT

Proposed the number 'zero' is undesirable in division operation, which causes the output to be undefined when it's placed in the denominator. Therefore, a zero detect circuit is necessary for each input before entering the operation.

The block diagram of a proposal quaternary detect zero is shown in Fig. 5 which uses three T-gates.

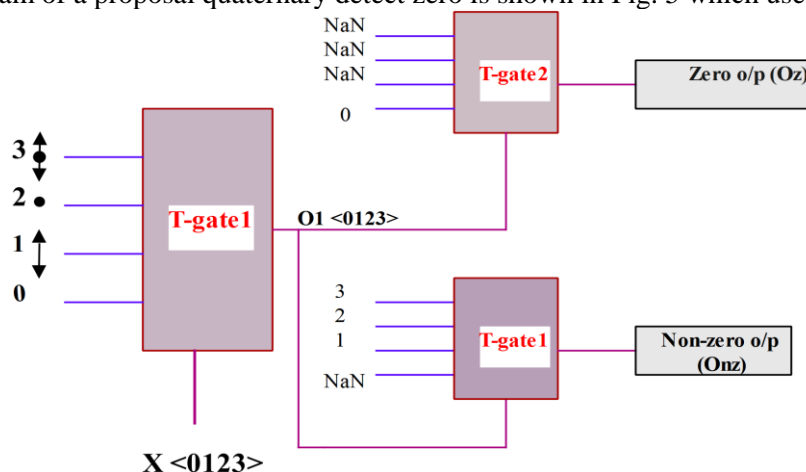

Figure 5. Quaternary detect zero circuit

The principle operation is of discrete detect-zero circuit is illustrated as:

CASE 1: If $X=0$ (no light), $O_1=0$, $O_z=0$ and $O_{nz}=NaN$.

CASE 2: If $X=1$ (vertical polarized light), $O_1=1$, $O_z=NaN$, $O_{nz}=1$.

CASE 3: If $X=2$ (horizontal polarized light), $O_1=2$, $O_z=NaN$, $O_{nz}=2$.

CASE 4: If $X=3$ (partial polarized light), $O_1=3$, $O_z=NaN$, $O_{nz}=3$.

The selection outputs (O_1 , zero O/P (O_z), and nonzero O/P (O_{NZ})) of the three T-gates used in the design can be expressed as:

$$O_1 = (0 \wedge X^{<3000>} + 1 \wedge X^{<0300>} + 2 \wedge X^{<0030>} + 3 \wedge X^{<0003>}) \quad (6)$$

$$O_z = (0 \wedge O_1^{<3000>} + NaN \wedge O_1^{<0300>} + NaN \wedge O_1^{<0030>} + NaN \wedge O_1^{<0003>}) \quad (7)$$

$$O_{NZ} = (NaN \wedge O_1^{<3000>} + 1 \wedge O_1^{<0300>} + 2 \wedge O_1^{<0030>} + 3 \wedge O_1^{<0003>}) \quad (8)$$

The operation of the circuit is illustrated in table 5.

Table 5. Truth table of discrete detect zero circuit

x	O ₁	O ₂	O _{NZ}
0	0	0	NaN
1	1	NaN	1
2	2	NaN	2
3	3	NaN	3

V. PROPOSED QUATERNARY DIVISION OPERATION WITH DISCRETE DETECT ZERO CIRCUIT

The quaternary division is intricacy operation and cannot implement when the zero number found in denominator because the result is undefined, so the discrete detect-zero circuit provides the possibility of implemented division operation.

Conventional safe quaternary division operation is implemented without getting NaN result. It's T-gate has four incoming data transmission lines (A, B, C, D) and one selection input [20]. Proposed the discrete detect zero circuit provided the possibility to reduce the number of incoming data transmission lines to three (A, B, C) therefore, reducing the storage memory, less number of optical mirror, and less power consumption. The quaternary optical division operation has been designed with seventeen T-gates is shown in Fig.6.

Quaternary division operation is defined by two functions given in table-6 where Q stands for modulo-4 quotient and R stands for modulo-4 remainder.

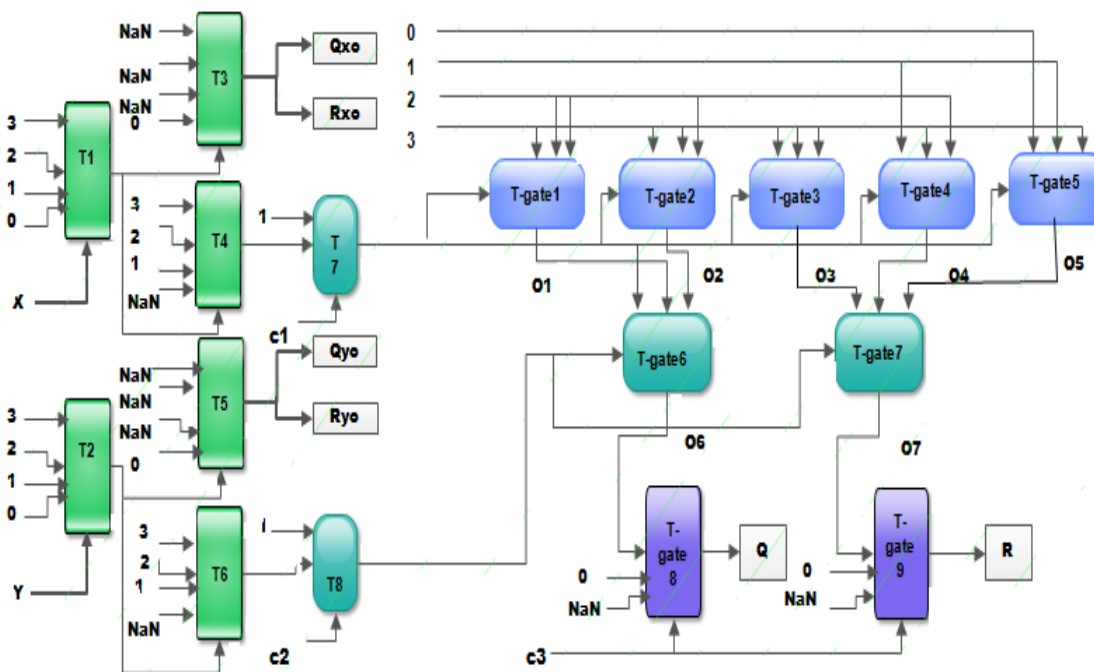

Figure 6. Quaternary division operation with discrete circuit of detect zero

The principle operation of quaternary division operation with discrete detect-zero circuit illustrate as:
 CASE 1: if X=0, Y=0, set C₁=C₂=1 and C₃=0 then, Q=NaN, R=NaN, but if Y=<123> then change C₂=0, C₃=1 and Q=0, R=0.

CASE 2: if X=1, Y=0, set C₂=1, C₃=0 then, Q=NaN, R=NaN, but if Y=<123> change C₂=0, C₃=2 and Q=<100>, R=<023>.

CASE 3: if X=2, Y=0, set C₂=1, C₃=0 and the outputs Q=NaN, R=NaN, but if Y=<123> then, change C₂=0, C₃=2, Q=<212>, and R=<002>.

CASE 4: if X=3,Y=0, set C₂=1, C₃=0 then, Q=NaN, R=NaN, but if Y=<123> then, C₂=0, C₃=2, Q=<311>, and R=<010>.

Note that NaN refer to not a number, Most operations propagate NaN without signaling exceptions, and signal the invalid operation exception when given a signaling NaN operand [21].

Table 6. Truth table of quaternary division i) quotient (Q) and ii) remainder (R)

X/Y	1	2	3
i)quotient(Q)			
1 (↓)	1	0	0
2 (●)	2	1	0
3 (⚡)	3	1	1
ii)Reminder(R)			
1 (↓)	0	2	3
2 (●)	0	0	2
3 (⚡)	0	1	0

The mathematical expressions according to Fig.6 are:

$$O_1=(0 \wedge x^{<300>} + 1 \wedge x^{<030>} + 1 \wedge x^{<003>}) \quad (9)$$

$$O_2=(0 \wedge x^{<300>} + 0 \wedge x^{<030>} + 1 \wedge x^{<003>}) \quad (10)$$

$$O_3=(0 \wedge x^{<300>} + 0 \wedge x^{<030>} + 0 \wedge x^{<003>}) \quad (11)$$

$$O_4=(2 \wedge x^{<300>} + 0 \wedge x^{<030>} + 1 \wedge x^{<003>}) \quad (12)$$

$$O_5=(3 \wedge x^{<300>} + 2 \wedge x^{<030>} + 0 \wedge x^{<003>}) \quad (13)$$

$$O_6=(x \wedge y^{<300>} + O_1 \wedge y^{<030>} + O_2 \wedge y^{<003>}) \quad (14)$$

$$O_7=(O_3 \wedge y^{<300>} + O_4 \wedge y^{<030>} + O_5 \wedge y^{<003>}) \quad (15)$$

The output equations of the quaternary division design can be expressed as:

$$Q=(O_6 \wedge C_3^{<300>} + NaN \wedge C_3^{<030>} + 0 \wedge C_3^{<003>}) \quad (16)$$

$$R=(O_7 \wedge C_3^{<300>} + NaN \wedge C_3^{<030>} + 0 \wedge C_3^{<003>}) \quad (17)$$

VI. RESULTS AND DISCUSSION

Result of numerical simulation of TOAD based detect zero circuit with MATLAB is shown in Fig. 7. In simulation, signal X = {0, 1, 2, 3}. The pulse shape is Gaussian in nature. It is clear from the results that the output is NaN in O_{nz} if X or Y input is zero and the output O_z is equal to zero as shown in fig. 7a, but if input is not equal to zero then, O_z is NaN and O_{nz} is equal value of X or Y as shown in fig. 7b.

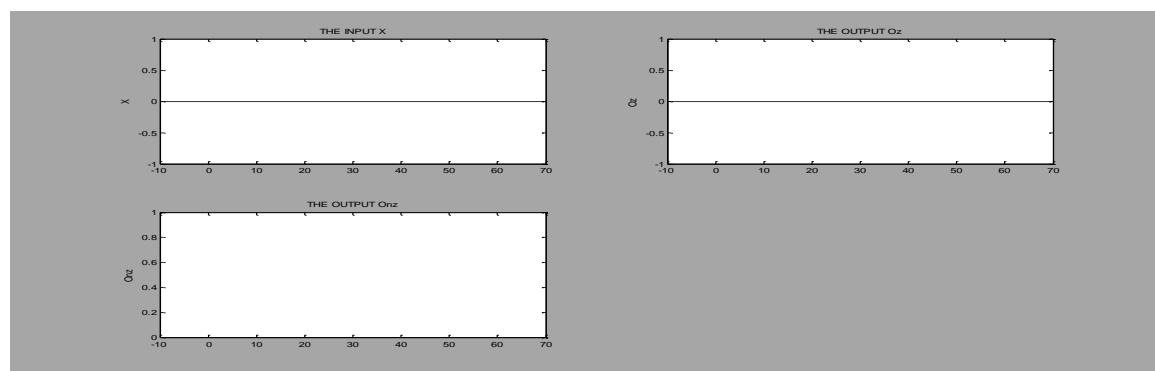

(a)

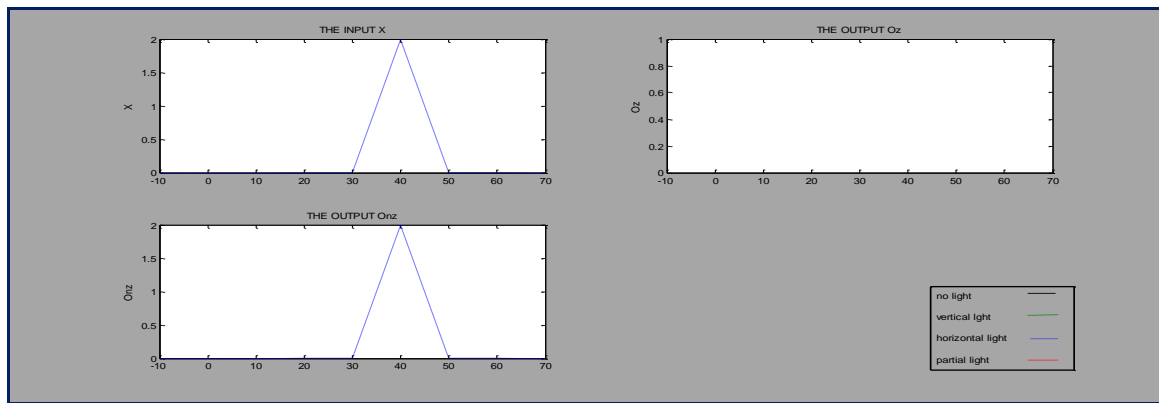

(b)

Figure 7. Simulated waveforms of detect zero operation

- (a) $X=0, O_z=0, O_{nz}=NaN$
- (b) $X=2, O_z=NaN, O_{nz}=2$

Figure 8 shows the simulation results of the quaternary division operation using discrete detect-zero for the inputs $X=<0123>$ and $Y=<0123>$. Simulation results for two cases are presented. In case the inputs are $X=0$ and $Y=0$, the outputs are $Q=NaN$ and $R=NaN$, see Fig. 8a. while for the inputs $X=3$ and $Y=2$, the outputs are ($Q=1$ and $R=1$) as shown in fig. 8b. Numerical simulation results verify the theoretical results.

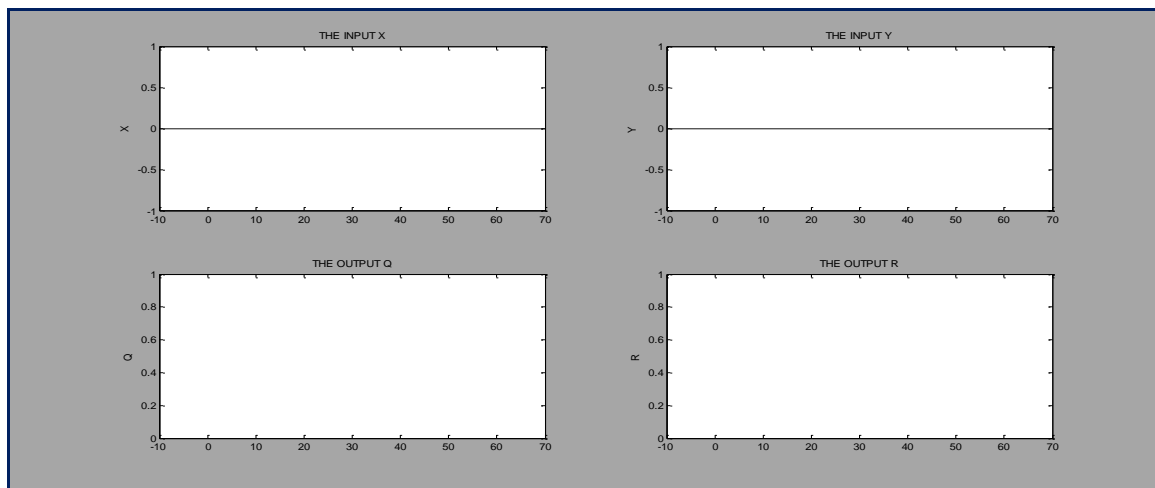

(a)

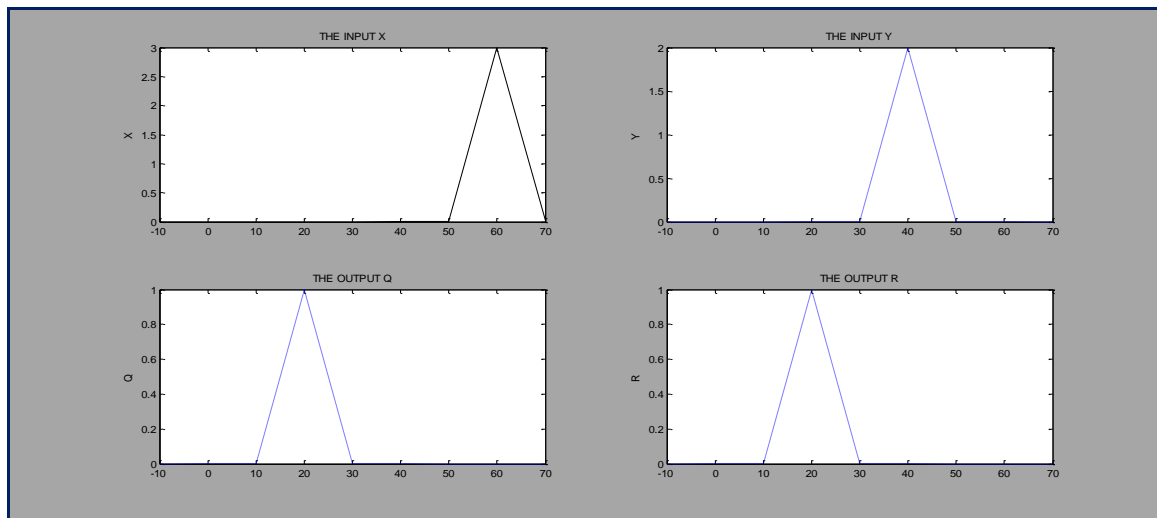

(b)

Figure 8. Simulated waveforms of quaternary division operation

(a) $X=0, Y=0, Q=NaN, R=NaN$

(b) $X=3, Y=2, Q=1, R=1$

VII. CONCLUSION AND FUTURE WORK

A design for quaternary division operation is presented in this paper. The design is based on discrete detect zero circuit. The significant advantage of this proposed scheme is that the logical operations, which can be performed, are all-optical in nature. The conventional design of T-gate used four incoming data transmission lines and one selection input but using the proposal discrete detect zero design reducing number of incoming data transmission lines to three. Laser of wavelength 1552 and 1534 nm can be used as input/control signal, respectively. The design of discrete detect zero circuit introduced new horizons for the basic arithmetic operation to reduce the number of T-gates and the number of incoming data transmission lines. For the future work the proposed design for detect zero can be easily and successfully extended to get a compact design of detect-zero circuit into which only one circuit is used. The scheme can also be improved by removing the controls in the quaternary division design led to reduction of the number of T-gates.

REFERENCES

- [1]. Nabil H. Farhat, "Photonic Neural Networks and Learning Machines", IEEE EXPERT, University of Pennsylvania, (Oct. 1992).
- [2]. P. Bruce Berra, , Arif Ghafoor, Mohsen Guizani, Slawomir J. Marcinkowski, and Pericles A. Mitkas, "Optics and Supercomputing ", IEEE, Vol. 77, No.12, (Dec. 1989).
- [3]. Bing C. Wang, Varghese Baby, Wilson Tong, Lei Xu, Michelle Friedman, Robert J.Runser, Ivan Glesk, and Paul R. Prucnal, "A novel fast optical switch based on two cascaded Terahertz Optical Asymmetric Demultiplexers (TOAD) ", Dept. of Electrical Engineering, Princeton University OPTICS EXPRESS 15, Vol. 10, No. 1, 14 Jan. (2002).
- [4]. Jitendra Nath Roy and Tanay Chattopadhyay, "All-Optical Quaternary Logic Based Information Processing: Challenges and Opportunities", *licensee InTech*, (2013).
- [5]. Dilip Kumar Gayen, Jitendra Nath Roy, Chinmoy Taraphdar, and Rajat Kumar Pal, "All-optical reconfigurable logic operations with the help of terahertz optical asymmetric demultiplexer", *Optik*, Vol. 122, pp. 711-718, (2010).
- [6]. Dilip Kumar Gayen, Jitendra Nath Roy, Chinmoy Taraphdar, Rajat Kumar Pal, "All-optical reconfigurable logic operations with the help of terahertz optical asymmetric demultiplexer", *optic*, vol. 122 , pp. 711-718, (2011).

- [7]. Tanay Chattopadhyay, Cláudia Reis, Paulo André, António Teixeira, "Theoretical analysis of all-optical clocked D flip-flop using a single SOA assisted symmetric MZI", Optics Communications, vol. 285, pp. 2266–2275, (2012).
- [8]. TanayChattopadhyay, JitendraNathRoy, " Design of polarization encoded all-optical 4-valued MAX logic gate and its applications", Optics Communications, vol. 300, pp. 119–128, (2013).
- [9]. Tamer. A. Moniem, Tanay C, "ALL OPTICAL BINARY DECODER AND ENCODER USING THE TERAHERTZ OPTICAL ASYMMETRIC DEMULTIPLEXER (TOAD)", Minia Journal of Engineering and Technology, Vol. 32, No.1, (Jan. 2013).
- [10]. Kristian E. Stubkjaer, " Semiconductor Optical Amplifier-Based All-Optical Gates for High-Speed Optical Processing", IEEE JOURNAL ON SELECTED TOPICS IN QUANTUM ELECTRONICS, Vol. 6, No. 6, Nov./Dec. 2000.
- [11]. V. M. Menon, W. Tong, C. Li, F. Xia, I. Glesk, P. R. Prucnal and S. R. Forrest, " All-Optical Wavelength Conversion Using a Regrowth-Free Monolithically Integrated Sagnac Interferometer", IEEE PHOTONICS TECHNOLOGY LETTERS, Vol. 15, No. 2, Feb. 2003.
- [12]. Ricardo Cunha, Henri Boudinov and Luigi Carro, "Quaternary Look-up Tables Using Voltage-Mode CMOS Logic Design", Brazil, IEEE, 2007.
- [13]. Dilip Kumar Gayen , Tanay Chattopadhyay, Rajat Kumar Pal, and Jitendra Nath Roy, " All-optical pretix tree adder with the help of terahertz optical asymmetric demultiplexer", CHINES OPTICS LETTERS, COL 9(6), Jun. 10, 2011.
- [14]. Tanay Chattopadhyay and Jitendra Nath Roy, "Polarization encoded TOAD based all-optical quaternary literals", Optik, Vol. 121, pp. 617–622, 2010.
- [15]. Tanay Chattopadhyay and Jitendra Nath Roy, "Design of polarization encoded all-optical 4-valued MAX logic gate and its applications", Optics Communications, Vol. 300, PP. 119–128, 2013.
- [16]. M. Eiselt, W. Pieper, and H. G. Weber, " SLALOM: Semiconductor Laser Amplifier in a Loop Mirror", JOURNAL OF LIGHTWAVE TECHNOLOGY, Vol. 13, No. 10, Oct. 1995.
- [17]. Tanay Chattopadhyay and Jitendra Nath Roy, "Polarization encoded all-optical quaternary successor with the help of SOA assisted Sagnac switch", Optics Communications, Vol. 284, pp. 2755–2762, 2011.
- [18]. Tanay Chattopadhyay and Jitendra Nath Roy, "Polarization-encoded all-optical quaternary multiplexer and demultiplexer – A proposal", Optik, Vol. 120, PP. 941–946, 2009.
- [19]. Jyoti Gujral and Vishu Goel, "Analysis of Augmented Gain EDFA Systems using Single and Multi-wavelength Sources", International Journal of Computer Applications, Vol. 47, No. 4, Jun. 2012.
- [20]. Tanay Chattopadhyay, "All-optical quaternary circuits using quaternary T-gate", Optik, Vol. 121, pp. 1784–1788, 2010.
- [21]. Microprocessor Standards Committee, "IEEE Standard for Floating-Arithmetic", New York, USA, IEEE, 29 Aug. 2008

AUTHORS

Alaa A. Al-Saffar was born in Basrah, Iraq, in 1957. He received the B.Sc, M.Sc and PHD from the University of Basrah, College of Engineering, Electrical Engineering Department in 1979, 1982 and 2001, respectively. His current research interests include optical computing and robotic control.



Doaa A. Karim was born in Basrah, Iraq, in 1990. She received the B.Sc from the University of Basrah, College of Engineering, Computer Engineering Department in 2011. Currently she is master student in University of Basrah, College of Engineering, Electrical Engineering Department.

