

## FUZZY PERT FOR PROJECT MANAGEMENT

<sup>1</sup>Thaeir Ahmed Saadoon Al Samman, <sup>2</sup>Ramadan M. Ramo Al Brahemi

<sup>1</sup>Assist. Prof, <sup>2</sup>Assistant Lecturer

College of Administration and Economics  
Management Information Systems Department  
University of Mosul, Iraq

### ABSTRACT

One of the most challenging jobs that any manager can take on in the management of a large scale project that requires coordinating numerous activities throughout the organization. A myriad of details must be considered in planning how to coordinate all these activities, in developing a realistic schedule, and then in monitoring the progress of the project. Fortunately, two closely related operations research techniques, PERT (program evaluation and review techniques) and CPM (critical path method) were developed in the 50's, within different contexts: the CPM was developed for planning and control of DuPont engineering projects and the PERT was developed for the management of the production cycle of the Polaris missile. They share the same objectives such as defining the project duration and the critical task. The PERT/CPM technique is based on two straight steps; a forward propagation to define the earliest start and finish dates (and subsequently the project duration and the free floats), and a backward promulgation for the latest start and finish dates (and the total floats). Initially, the activity times are static within the CPM technique and probabilistic within the PERT technique. Over the last few decades, both CPM and PERT techniques have been universal to fuzzy and stochastic areas. To treaty with uncertainty in project management. Predominantly, Fuzzy PERT and CPM are to be deliberated to treaty particularly with fuzzy planning. On the antagonistic to PERT/CPM technique that ignores any consideration of resources, other Fortuitously, two closely related operations research techniques, PERT (program evaluation and review techniques) and CPM (critical path method) are presented to assist the project manager in carrying out these responsibilities PERT/cost is a systematic produce (normally computerized) to help the project manager plan schedule, and control projects cost. The PERT/cost produce begins with the hard work of developing an estimate of the cost each activity when it is performed in the planning way (including any crashing).

We propose to improve PERT by using Fuzzy Delphi for estimating  $T1$ ,  $Tm$ , and  $T3$  for each activity the fuzzy PERT is illustrated and give case study in readymade factory. The result of the proposed model and time-cost tradeoff. In the next section proposed model is more thoroughly defined, this proposed model is more thoroughly defined. This is followed by the application of the fuzzy logic to Pajamas in reaty wear(clothing) factory In Mosul. PERT/cost is a systematic produce (normally computerized) to help the project manager plan schedule, and control projects cost. The PERT/cost produce begins with the hard work of developing an estimate of the cost each activity when it is performed in the planning way (including any crashing).we propose to improve PERT by using Fuzzy Delphi for estimating  $T1$ ,  $Tm$ ,  $T3$  for each activity the fuzzy PERT is illustrated and give case study in readymade factory.

**KEY WORDS:** PERT, CPM, FUZZY LOGIC, PROJECT MANAGEMENT

### I. INTRODUCTION

Many of industrial projects assign many of available physical resource to types of activities that needs many times in achievement their project related to development project, building, research, production visible and defense which needs large capability in planning and scheduling different activities (Riggs, 1997) [15].

In this research two method in used successfully in planning for many large project which is called PERT and CPM, especially when the project activities have to be performed in specified technological sequences(Raviradrama, A., *et. al.*,1987) [26].

Project Management is a complicated enterprise involving planning of various activity which have to be performed in the process of development of new product or technology.

Project have a specified beginning and end for convenience they are subdivided in to activities Which also have specified beginnings and ends. The activities have to be performed in order , Some before others , Some simultaneously , the time required for completion of each activity has to be estimated (George B. and Bojadziev , M , p78)[12].

The basic form of PERT& CPM focus on identifying the Longest time Consuming path through a networks of tasks as a basic for planning and Controlling a project (Mark M . Davis *et. al.* , 2003 . p94) [9]. The Critical Path Method is one of the project scheduling specificities. The majority of the research on the project scheduling topic has been devoted to fuzzy PERT , As explained before, the PERT technique is composed of two steps; the forward and the backward propagations.(Masmoudi,M, Erwin Hans, and Alain Haït,2011) [23].

The generalization of the PERT technique to fuzzy parameters is a complex task. The forward propagation is done using fuzzy arithmetic, leading to fuzzy earliest dates and a fuzzy end-of-project event. Unfortunately, backward propagation is no longer applicable because uncertainty would be taken into account twice.( Chanas *et al.*, 2002) [20].study the criticality of tasks within fuzzy project.( Dubois *et al.*, 2003) [6]. Show that the boundaries of some fuzzy parameters like the tasks' latest dates and floats are reached in extreme configurations

Expanding the PERT mode to take cognizance of the fact that Fuzzy logic on project activities is taking place at varying rate adds complexity to the model. Now the time to complete a Unit is a function of two variable, namely:

1. The number of Time the various activities have been repeated on prior runs of the project.
2. Fuzzy Logic of each time activity However, this complexity can be readily by computerizing the model.

The model use under the following condition:

1. The time of an activity has been completed on project runs is not same for all activities comprising the network. This is the resultant of repeating a partially repeating a partially repetitive project.
2. Fuzzy logic is tested for charge in project completion times when fuzzy logic take place on all activities.

The result of the proposed model and time-cost tradeoff. In the next section proposed model is more thoroughly defined, this proposed model is more thoroughly defined. This is followed by the application of the fuzzy logic to Pajamas in realty wear (clothing) factory In Mosul.

Fuzzy set through represent an attractive tool to aid research in production management, when the Dynamic of the production Environment limited the specification of model objectives ,constraints and the precise measurement of model parameters . Enabled us to apply the proposed model to determine the times of the implementation of the new product A Pajamas in factory clothes in Mosul and through the identification of activities, the main constituent of this Delphi a project and relationships precedence between the various activities and the time required to implement each of the activities which have been determined by experts using the Delphi method, where been identified time optimistic and pessimistic and most likely time and were then used Fuzzy logic to determine these times and then determine the cost and then we calculate the critical path, which includes all the critical activities that cause a delay in which the delay in the completion of the final product as well as identify times of accelerating and associated costs have reached an a set of conclusions and recommendations.

## **II. RELATED WORK**

Traditionally, scheduling theory has been concerned with allocation of resources to tasks or activities (Parker, 1995) [20]. On the area of scheduling, fast progress concerning models and methods has been made. Two techniques of resource management, namely:

- 1- Resource-constrained project scheduling , unambiguously takes into account constraints on resources and aims at scheduling the activities subject to the precedence constraints and the resource constraints in order to minimize the project duration. Resource-constrained project scheduling problem is one of the most attractable classical problems in practice. Multiple exact techniques and heuristics and a number of meta-heuristics have been applied to solve the RCPSPP problem .
- 2- Resource leveling, takes into account the superiority constraints between the activities, and aims at completing the project within its due date with a resource usage which is as leveled as possible throughout the project duration.( Herroelen, 2007) [23].

Several studies have investigated the case where activity times in a project are approximately known and more appropriately represented by fuzzy sets rather than crisp numbers. ( Lorterapong, P., & Moselhi ,O., 1996,308-318) [22]. (D. Dubois, H. Fargier, V. Galvagonon, 2003, 266-280) [6].

In specific, the problems of computing the intervals of possible values of the latest starting times and floats of activities with vague durations represented by fuzzy or interval numbers have fascinated intensively attentions and many solutions methods have been suggested. (P. Zielinski, 2005, 53-76) [8].(D. Dubois, H. Prade, 1978, 613-626) [25].

Most of them are straight forward postponements of deterministic CPM. They are mainly based on the CPM with formulas for the forward and backward recursions, in which the deterministic activity times are replaced with the fuzzy activity times. However, as noted by Zielinski [3], the backward recursion fails to compute the sets of possible values of the latest starting times and floats of activities. Moreover, for the same path, different definitions of the fuzzy critical path give different estimations of the grade of criticality.

Dubois et al. proposed several heuristics for computing the sets of possible values of the latest starting times and floats of activities using rigorous formulation of fuzzy PERT. Zielinski [3] developed new polynomial algorithms for determining the intervals of the latest starting times in the general network. Chanas and Zielinski [3] discussed the complexity of criticality, Chanas and Zielinski [3] proposed a natural generalization of the criticality concept for project networks with interval and fuzzy activity times, in which two methods of calculating the degree of possible criticality and some results are provided. The advantage of this method is that it prevents fuzzy numbers from getting larger and also the result of subtraction of each fuzzy number from itself is crisp zero [11].

(C.T . Chen *et al.*,)[2] proposed a method to deal with completion time management and the critical degrees of all activities for a project network[3] [11]. Chen and Haung[2] also proposed an approach using positive triangular fuzzy number. This method however does not support backward pass calculations in direct manner similar to that used in the forward pass. This is mainly due to the fact that fuzzy subtraction is not proportionate to the inverse of fuzzy addition .Therefore, this method is incapable of calculating project characteristics such as the latest times. (K. Usha Madhuri, S. Siresha and N. Ravi Shankar, 2012, 1303 – 1324) [17].

Van Drop and Kotoz include the two sided power (TSP) Distribution in the PERT methodology making use of the advantages that this four- parameter distribution offers . In order to be completely determined , distribution of this type needs , the same as the Beta Distribution anew department from the three usual values optimistic ,pessimistic , most likely (van drop and Kotoz , 2002 b , 562)[10]

(J.Jassbi and S. Khan Mohammadi ) [16] Introduce a new approach for predicting and analysis of the project duration using fuzzy durations and fuzzy possibilities , the Beta probability is changed to beta probability distribution function(12) .(Yao et al. ,) [27].used signed distance ranking of fuzzy numbers to find critical path in fuzzy project Network. (Chen *et al.*,) [2]used defuzzification method to find possible critical paths in fuzzy project Network.(S. Chanas and zielinski) [3]. assume that the cooperation time of each activity can be represented as a crisp value , interval or a fuzzy number . (D . Dubois , H . Fargier , V. Galvagonon) [3].

### III. FUZZY PERT FOR TIME FORECASTING

We propose to improve PERT by using Fuzzy Delphi method is a generalization of the classical method for long range forecasting in management science known as Delphi method. It was developed

in the sixties by the Rand Corporation at Santa Monica, California. The name comes from the ancient Greek oracles of Delphi who were famous for forecasting the future. The essence of Delphi method can be described as follows:

1. Experts with high equalizations regarding a subject are requested to give their opinion separately and independently of each other about the realization dates of a certain event, say in science, technology, or business. They may be asked to forecast the general state of the market, economy, technological advances, etc.
2. The data which have subjective character are analyzed statistically by finding their average and the results are communicated to the experts.
3. The experts review the results and provide new estimates which are analyzed statistically and sent again to the experts for estimation. This process could be repeated again and again until the outcome converges to a reasonable solution from the point of view of a manager or a governing body. Usually two or three repetitions are sufficient.

The Fuzzy Delphi Method is an analytical method based on the Delphi Method that draws on the ideas of the Fuzzy Theory. The Delphi Method is a type of collective decision-making method (Linstone & Turoff, 2002) [20]. with several rounds of anonymous written questionnaire surveys conducted to ask for experts' opinion. As a direct prediction method based on the expert judgment and expert meeting investigation method, it possesses the following properties:

1. Anonymity: The experts involved with the prediction process do not see each other, remain anonymous and don't know how many experts are involved. This helps to prevent them from influencing and encourages objectivity.
2. Feedback: The survey feedback gives the participants an idea about the main ideas in the group. They can then draw from it information relevant to them, make a new judgment, and then submit it to the group again.
3. Statistical: The expert opinions are processed statistically and a splines graph produced with the expert opinion frequencies arrayed chronologically. The top is the majority consensus (50% experts) representing the prediction team's opinion. The top and bottom quarter percentile (each representing 25% of the experts) represent the prediction deviation.
4. Convergence: Through multiple reverse feedback make the final prediction results converge. (Yu-Feng Ho, Hsiao-Lin Wang) [28].

However, long range forecasting problems involve imprecise and in-complete data information. Also the decisions made by the experts rely on their individual competence and are subjective. Therefore it is more appropriate the data to be presented by fuzzy numbers instead of crisp numbers. Especially triangular numbers are very suitable for that purpose since they are constructed easily by specifying three values, the smallest, the largest, and the most plausible. Instead of crisp average, the analysis will be based on fuzzy average.

The Fuzzy Delphi method was introduced by Kaufman and Gupta (1988). It consists of the following steps [19] [12] :

**Step 1 :** Experts  $E_i$ ,  $i = 1, \dots, n$  are asked to provide the possible realization dates of a certain event in science, technology, or business, namely: the earliest date  $a_1^i$ , the most plausible date  $a_m^i$  and the latest date  $a_2^i$ . The data given by the experts  $E_i$  are presented in the form of triangular numbers

$$A_i = (a_1^i, a_m^i, a_2^i), i = 1, \dots, n \quad \dots \quad (1)$$

**Step 2 :** First, the average (mean)  $A_{ave} = (m_1, m_M, m_2)$  of all  $A_i$  is computed

$$A_{ave} = (m_1, m_M, m_2) = \left( \frac{1}{2} \sum_{i=1}^n a_1^{(i)}, \frac{1}{n} \sum_{i=1}^n a_m^{(i)}, \frac{1}{n} \sum_{i=1}^n a_2^{(i)} \right) \quad \dots \quad (2)$$

Then for each expert,  $E_i$  the deviation between  $A_{ave}$  and  $A_i$  is computed. It is a triangular number defined by

$$\begin{aligned} A_{ave} - A_i &= (m_1 - a_1^{(i)}, m_M - a_m^{(i)}, m_2 - a_2^{(i)}) \\ &= \left( \frac{1}{n} \sum_{i=1}^n a_1^{(i)} - a_1^{(i)}, \frac{1}{n} \sum_{i=1}^n a_m^{(i)} - a_m^{(i)}, \frac{1}{n} \sum_{i=1}^n a_2^{(i)} - a_2^{(i)} \right) \quad \dots \quad (3) \end{aligned}$$

The deviation  $A_{ave}-A_i$  is sent back to the expert  $E_i$  for reexamination.

**Step 3 :** Each expert  $E_i$  presents a new triangular number :

$$B = (b_1^{(i)}, b_M^{(i)}, b_2^{(i)}), \quad i = 1, \dots, n \quad \dots\dots(4)$$

This process starting with Step 2 is repeated. The triangular average  $B_m$  is calculated according to formula :

$$\begin{aligned} A_{ave} = (m_1, m_m, m_2) = A_{ave} - A_i &= (m_1 - a_1^{(i)}, m_M - a_m^{(i)}, m_2 - a_2^{(i)}) \\ &= \left( \frac{1}{n} \sum_{i=1}^n a_1^{(i)} - a_1^{(i)}, \frac{1}{n} \sum_{i=1}^n a_m^{(i)} - a_m^{(i)}, \frac{1}{n} \sum_{i=1}^n a_2^{(i)} - a_2^{(i)} \right) \quad \dots\dots(5) \end{aligned}$$

with the difference that now a  $a_1^{(i)}, a_M^{(i)}, a_2^{(i)}$  are substituted correspondingly by  $b_1^{(i)}, b_M^{(i)}, b_2^{(i)}$ . If necessary, new triangular numbers  $c^{(i)} = (c_1^{(i)}, c_M^{(i)}, c_2^{(i)})$  are generated and their average  $C_m$  is calculated. The process could be repeated again and again until two successive means  $A_{ave}$ ,  $B_{ave}$ ,  $C_{ave}$ , become reasonably close.

**Step 4 :** At a later time the forecasting may be reexamined by the same process if there is important information available due to new discoveries.

Fuzzy Delphi method is a typical multi-experts forecasting procedure for combining views and opinions.

We propose to improve PERT by using Fuzzy Delphi For estimating  $t_1, t_M, t_2$  for each activity. Experts represent each time for

activity completion by triangular numbers of the type  $(t_1, t_M, t_2)$ . For each activity the triangular average number is calculated. To defined a crisp activity time value we have to use defuzzification. Simply we may take the maximizing value ( $X_{max} = m_M$ ) or resort to the average formulas (5)(1)-(3). With the difference that now  $a_1^{(i)}, a_m^{(i)}, a_2^{(i)}$  are substituted correspondingly by  $b_1^{(i)}, b_m^{(i)}, b_2^{(i)}$ . If necessary, new triangular numbers  $c^{(i)} = (c_1^{(i)}, c_m^{(i)}, c_2^{(i)})$  are generated and their average  $C_m$  is calculated, The process could be repeated again and again until two successive means  $A_{ave}$ ,  $B_{ave}$ ,  $C_{ave}$ , become reasonably close

$$X_{max} = m_M \quad \dots\dots (6)$$

$$(1) X_M^{(1)} = \frac{m_1 + m_M + m_2}{3} \quad \dots\dots(7)$$

$$(2) X_{MAX}^{(2)} = \frac{m_1 + 2m_M + m_2}{4} \quad \dots\dots(8)$$

$$(3) X_{MAX}^{(3)} = \frac{m_1 + 4m_m + m_2}{6} \quad \dots\dots(9)$$

The project scheduling research and development of new product (Pajamas) in ready wear factory in Mosul. In order to complete this project, we will need information from the factory research and development product testing, manufacturing, cost estimating and market research groups.

**Table (1)** Description of the Pajamas production process

Activity	Description	Immediate predecessors	Optimistic	Most probable	Pessimistic
A	R& D Product design	-	4	5	12
B	Plan market research	-	1	1.5	5
C	Routing	A	2	3	4
D	Build prototype model	A	3	4	11
E	Prepare marketing, brochure	A	2	3	4
F	Cost estimate	C	1.5	2	2.5
G	Preliminary product testing	D	1.5	3	4.5

H	Market Surray	B,E	2.5	3.5	7.5
I	Pricing and Far cost report	H	2	2	2.5
J	Final report	F,G,I	2	2	3

**Table (2)** Improved network Planning model using Fuzzy PERT

Activity	Normal time	Crash time	Normal Cost $C_n$ max	Crash cost $C_C$ max	Cost slope
A	5	4	1000000	1500000	500000
E	3	2	500000	750000	250000
H	3.5	2.5	1500000	2000000	500000
I	2	1.5	300000	400000	2000
J	2	1	250000	300000	50000

**Table (3)** Normal and crash time and cost of critical activity

Activity	Normal time	Crash time	Normal Cost \$	Crash cost
A	5	3	20000	26000
E	3	2	30000	40000
H	3.5	2	28000	30000
I	3.5	2	28000	30000
J	2	1	15000	19000

The cost slope coefficient calculated for activity A gives

$$K_A = \left| \frac{C_{n\max} - C_{c\max}}{T_{n\max} - T_{c\max}} \right| = \left| \frac{100000 - 1500000}{5 - 4} \right| = 500000$$

**Table (4)** Pajamas Network PERT calculation

Activity time	Activity	Average Activity	Optimistic time $t_1$	Most likely time $t_m$	Pessimistic time $T_2$
$T_{ave}^A$	A	$T_{ave}^A$	4	5	12
$T_{ave}^B$	B	$T_{ave}^B$	1	1.5	5
$T_{ave}^C$	C	$T_{ave}^C$	2	3	4
$T_{ave}^D$	D	$T_{ave}^D$	3	4	11
$T_{ave}^E$	E	$T_{ave}^E$	2	3	4
$T_{ave}^F$	F	$T_{ave}^F$	1.5	2	2.5
$T_{ave}^G$	G	$T_{ave}^G$	1.5	3	4.5
$T_{ave}^H$	H	$T_{ave}^H$	2.5	3.5	7.5
$T_{ave}^I$	I	$T_{ave}^I$	1.5	2	2.5
$T_{ave}^J$	J	$T_{ave}^J$	1	2	3
			11	15.	29

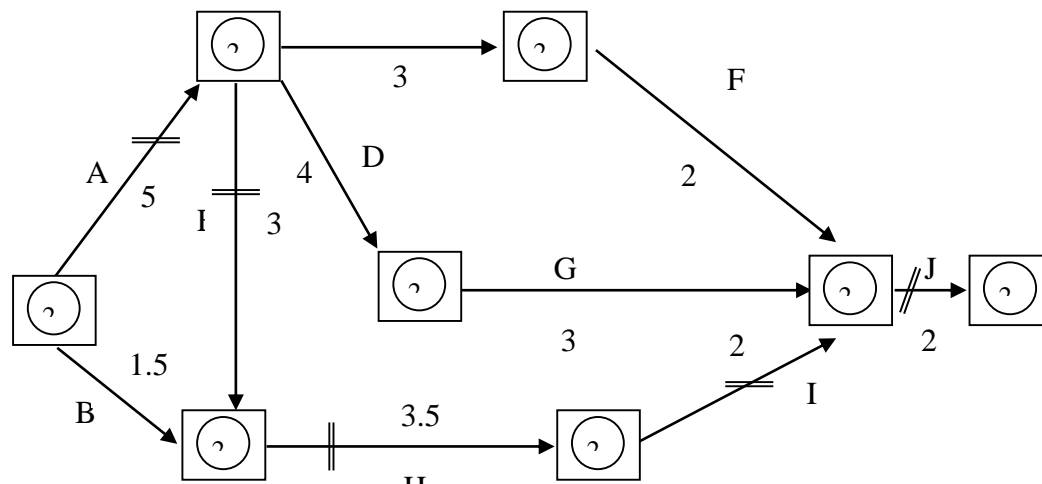

Fig (1) Pajamas network

Each triangular number representing the average activity time ( the second column in label 4 ) has to be defuzzified to produce a crisp number expressing the activity completion tome . These Triangular number are almost in central form , hence we can apply formula ( 6 ) for defuzzication which produces the number in the fourth column labeled  $T_M$  the use of formulas (7,8,9) gives close results . The defuzzified times can be presented in an improved network planning model ( fig 1 )

The total time for project completion expressed by the triangular number  $T$  is the time for completions the activities on the Critical path . Adding the numbers on the three Columns in Table 4 designated by  $t_1 , t_m , t_2$  , excluding those belonging to activities B and D , gives

$$T = T_{ave}^A + T_{ave}^E + T_{ave}^H + T_{ave}^I + T_{ave}^J = (1,15.5,29)$$

Hence the project duration will be between 11 days and 29 days , most likely 15.5 days . The last number 15.5 days is the result of defazzication generates the Crisp Numbers :

$$T_{max}^{(1)} = \frac{m_1 + m_m + m_2}{3} = \frac{11 + 15.5 + 29}{3} = 18.5$$

$$T_{max}^{(2)} = \frac{m_1 + m_m + m_2}{4} = \frac{11 + 2 \times 15.5 + 29}{4} = 17.75$$

$$T_{max}^{(3)} = \frac{m_1 + 4m_m + m_2}{6} = \frac{11 + 4 \times 15.5 + 29}{9} = 17$$

They are close to ( 17.75 ) , As a conclusion the completion time for the project is forecasted to be ( 17.75 ) days , If the triangular number A are is close to a central triangular number , meaning that  $m_m$  is almost in the middle of (  $m_1, m_2$  ) , then (6) gives a good crisp value  $X_{max} = m_m$  . then the three average formulas (1) – (3) in (7,8,9) also produce number ( maximizing values ) close to  $m_m$  hence there is no need to be used usually in applications the triangular average numbers appear to be in central form . however , the experts dealing with a given situation have to use their judgment when selecting a maximizing value Following PERT we introduce the notations  $t_n$ -normal time for completing an activity .

$C_n$  – normal cost for completing an activity

$C_c$  – Crash cost ( increased cost ) for completing an activity in crash time.

We illustrate here Fuzzy PERT for Shortening project length on the introduce new product . To shorten project length means to shorten the time for completion the critical path , i.e to shorten the total time  $T_{max} = 117$  days .Shortening duration time of activities not on the critical path and ( A , D , G , J), ( B , H , I , J ) . Will not reduce  $T_{max}$  , However some resources allocated to (A,C,F,J) , (A,D,G,J) ( B , H , I , J ) could be reallocated to activities ( A , E , H , I , J ) in order to shorten their completion time ( internal reallocation ) . Here we consider shortening activities time on the critical path without internal reallocation of recourses.

The normal time  $t_n$  for each activity is already estimated it is the time

$T_{max} = t_m$  shown in table 3.7 the fourth column .

The crash time  $t_c$  , the normal cost  $C_n$  , and the crash Cost  $C_c$  for each activity could be forecasted Similarly to the normal time  $t_n$  applying Fuzzy Delphi

The defuzzified values based on formula ( 6 ) will be denoted by  $t_c \text{ max}$  , and  $C_c \text{ max}$  correspondingly .

Here estimation is presented for the normal Cost  $C_c$  can be estimated similarly .

Three experts are asked to estimate the normal Cost for completion activity A in the form of a triangular number C

$C_n = ( C_{n1} , C_{nm} , C_{n2} )$  , where  $C_n$  , is Cost , and  $C_{n2}$  is the highest cost .

Assume the experts estimates are those in table 5.

$$A_{ave} = ( m_1 , m_M, m_2 )$$

$$A_{ave} = \left( \frac{1}{n} \sum_{i=1}^n a_1^{(i)} , \frac{1}{n} \sum_{i=1}^n a_m^{(i)} , \frac{1}{n} \sum_{i=1}^n a_2^{(i)} \right)$$

$$X_{max} = M_m$$

$$X_{max}^{(1)} = \frac{m_1 + m_m + m_2}{3}$$

$$X_{max}^{(2)} = \frac{m_1 + m_m + m_2}{4}$$

$$X_{max}^{(3)} = \frac{m_1 + 4m_m + m_2}{6}$$

**Table 5** Experts estimate for completion activity A at normal Cost  $C_n$

Expert	Lowest cost $C_{n1}$	Most likely cost $C_{nm}$	Highest cost $C_{N2}$
E1	20000	22000	25000
E2	21000	23000	26000
E3	19000	20000	24000
total	60000	65000	75000

Using formula ( step 2) gives the average normal cost  $c_{nave}^A$  are the decimals and rounding off the last three digits to 000, 500 , or 1000 , gives

$$c_{nave}^A = (20000,21000,25000)$$

Further , groups of experts , forecast  $t_c$  ,  $C_c$  and  $C_c$  for the other activities on the critical path , then defuzzuffy , and round off as above .

Assume that the defuzzified results for the activities on the critical path are those presented in table (6) .

To select activities for shortening duration time , PERT uses the notion of cost slope , with our notations it is presented as ( see fig 2 )

$$K = \text{cost slop} = \left| \frac{C_n \text{ max} - C_c \text{ max}}{t_n \text{ max} - t_c \text{ max}} \right| \dots\dots\dots (11)$$

Fig (2) shows that as normal time  $t_n \text{ max}$  decreases approaching the crash time  $t_c \text{ max}$  , the normal cost  $C_n \text{ max}$  increases approaching the crash cost  $C_c \text{ max}$  . The cost slope fig (2) calculated for activity A give :



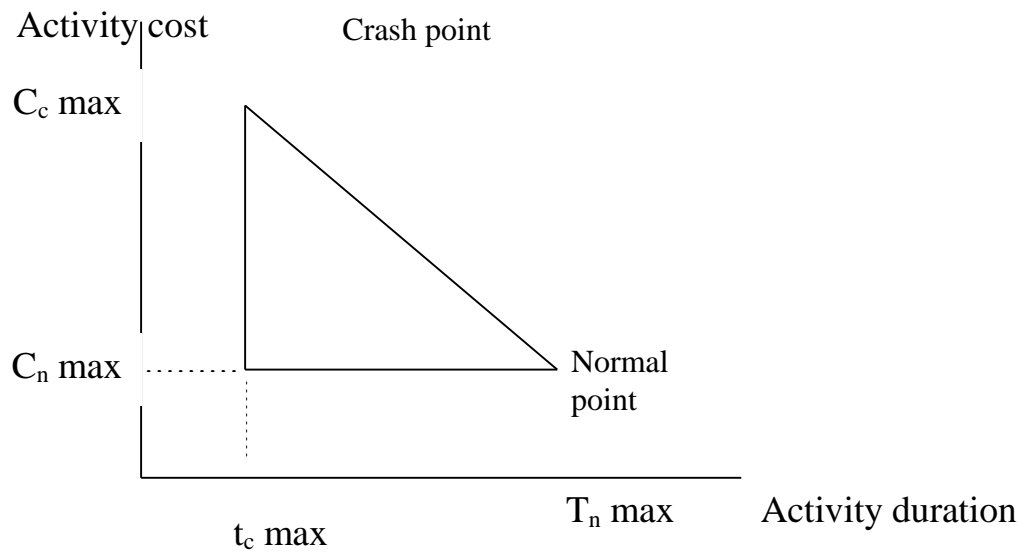

Fig(2) Cost Slope

Table 6 Defuzzified normal and crash times , and cost for activities in New product planning

Activity	Normal Time $t_n \text{ max}$	Time $t_c \text{ max}$	Cost $C_n \text{ max}$	Crash cost $C_c \text{ max}$	Cost slope \$ per day
A	5	3	20000	26000	3000
E	3	2	30000	40000	10000
H	3	2	28000	30000	2000
I	2	1	18000	25000	7000
J	2	1	15000	19000	4000

The cost slope coefficient for the other activities are Calculated similarly . the results are displayed in the last column of table 6 .

In general additional resources should be applied first to activities with smallest cost slope .

The activities in table 6 are ranked in table 7 according to their cost slopes from the smallest to be the largest .

Table: 7 Ranked activities according to cost slope .

Rank	Activity	Reduced time $T_n \text{ max} - t_c \text{ max}$	Additional cost $C_n \text{ max} - C_c \text{ max}$	Cost slope \$ per day
1	H	1	20000	2000
2	A	2	60000	3000
3	J	1	4000	4000
4	I	1	7000	7000
5	E	1	10000	10000

Assume that the management wants to reduce the length of the project from 117 days to 107 days , a reduction of (10) days, of the activities on the critical path , activity H ranked first ( Table 7 ) has the

smallest K , \$ 2000 per day By investing \$ 20000 the time duration for activity H can be reduced by 10 days .

A further reduction of ( 10 ) days must be found a good candidate is activity A ranked will cost on Table 7 .A 10 day reduction will cost  $10 \times 3000 = 30000$  dollars , However , if there are some reason against shortening the activity tome for H or for A m or for both , other Options must be examined .

#### IV. CONCLUSION

PERT methodology aims to estimate the mean and the variance of a random variable , of which only the values a (pessimistic) , , m (most likely) , and p (optimistic) – supplied by an expert, are Known and for which an underlying beta distribution is assumed .to obtain the estimate at the mean it is only required that this (standardized beta ) distribution is mesokurtic ( $B_2=3$ ) or of constant variance(-1/36).The main goal of this paper is to get an optimal PERT susing Fuzzy Logic.

The issues considered while selecting a PERT as total minimum cost taken for a project to complete ,manpower required to complete the project , function points required to complete it .All three constraints are crashed an time basis .the constraints are crashed by considering the crashed time only .Now the optimal PERT is to be selected using Fuzzy Logic. We developed fuzzy expert system which is used select an optimal PERT chart. optimality is described here with in the rules of Fuzzy Logic. We have used anew defuzzification formula for trapezoidal fuzzy number and applied to the float time for each activity in the fuzzy project network to find the critical path.

Considering the problem of Pajamas' project management in the readymade factory in Mosul, this research is also devoted on the fuzzy PERT/cost analysis of activity durations. then the critical path of the fuzzy PERT/cost will be achieved.

#### REFERENCES

- [1] Abuja, H. N. , Dozzi, S .p. and Abourizk, S. M. , 1994, project Management , Wiley, New York.
- [2] C.T. Chen, S.F. Huang, Applying fuzzy method for measuring criticality in Project network, Information sciences ,177 (2007) 2448- 2458.
- [3] Chanas, S. P. Zielinski , 2001,critical path analysis in the network with fuzzy task time ,Fuzzy sets and systems0-61),195-204.
- [4] Chanas, S., Dubois, D., Zielinski, P., 2002. Necessary criticality in the network with imprecise activity times. IEEE Transactions on Systems, Man and Cybernetics 32, 393–407.
- [5] Chen, S. M. and Chang, T.H. 2001, Finding Multiple possible critical paths using Fuzzy PERT, IEEE Transactions on systems ,man and cybernetics- part A:systems and humans ,vol.31,no.6.
- [6] Dubois, D., Fargier, V Avagonon, H.,V., 2003, on latest starting times and floats in task networks with ill-know durations. European Journal of operational research 145,10 t 3,266-280.
- [7] Dubois, D. and Prade , H., 1988, possibility theory : Approach to computerized processing of uncertainty ,plennm N.4
- [8] D. Dubois, H. Prade , (1978) Operations on fuzzy numbers, International Journal of systems science, 30 , 613-626.
- [9] Davis , Mark M ., Nicholas J , Aquilano and Richard B , Chase , 2003 Fundamental of Operation Management , 4th, McGraw – Hill , Irwin , P 94.
- [10] Drop JR, Van , Kotoz S (2002b) the standard two sided power distribution and its properties :with applications in financial engineering ,the American statistician :90 -99, p562.
- [11] N. Ravi Shankar, V. Sireesha and P. Phani Bushan Rao, An Analytical Method for Finding Critical Path in a Fuzzy Project Network.
- [12] George Bojadziev & Maria Bojadziev, 2007, Advances in Fuzzy system : Application and Theory Fuzzy logic for Business , finance , and management , 2<sup>nd</sup> ed . vol., 23. World Scientific publisher Co. Pte. Ltd. p78.
- [13] Guiffrida , Alfred L . and Nagi, Rakesh., Fuzzy set theory Applications , in production Management Research A Literature Surrey p.2-3.
- [14] Hapke , M. and Slowinski, R., 1996, Fuzzy priority heuristics for project scheduling, fuzzy sets and systems, vol. 83 , no.3,pp.291-299.
- [15] James L .Riggs , 1987 , production system : planning , Analysis , and control , 4th ed , john Wiley & Sons , New York .
- [16] Jassbi, J. and Mohammadi , S.Khan ,A new Approach for predicting project duration using Beta shape membership function sand simulation.

- [17] K. Usha Madhuri, S. Siresha and N. Ravi Shankar, 2012, A New Approach for Solving Fuzzy Critical Path Problem Using L-L Fuzzy Numbers,
- [18] Kaufman , A , and Gupta M .M (1985) ,Fuzzy mathematical Models in Engineering and Management Science .
- [19] Kaufman , A .and Gupta , M .M ,1988 , Introduction to Fuzzy Arithmetic : theory and Application , van no strand Reinhold , New York.
- [20] Linstone, H. A., & Turoff, M., ed, 2002, The Delphi Method: Techniques and Applications, ISBN 0-201-04294-0.
- [21] Lootsma, F.,1989. Stochastic and fuzzy PERT. European Journal of Operational Research 43,174–183.
- [22] Lorterapong, P., & Moselhi,O. (1996) Project-network analysis using fuzzy sets theory. Journal of Construction Engineering Management,122, 308-318.
- [23] Malek , Erwin Hans, and Alain Haït. Fuzzy tactical project planning: Application to helicopter maintenance. In the 16th IEEE International Conference on Emerging Technologies and Factory Automation ETFA'2011, Toulouse, France, September 2011. (Cited on pages 24, 25,44,48,49,51,56).
- [24] Mon, D. L., Chengs C,H. and Lu, H. C. , 1995, Application of fuzzy distribution on project management , fuzzy sets and systems, vol. 73, no.3pp227- 234.
- [25] P. Zielinski, (2005) On computing the latest starting times and floats of activities in a network with imprecise durations, Fuzzy Sets and Systems 150, 53-76.
- [26] Ravindran A, Philips Don T ., & James J Solberg ,1987 , operations research , Principles, 2nd ed., John Wiley & Sons, M. Y .
- [27] YAO, J .S., and Lin , F.T., 2000 Fuzzy critical path method Based on Signed Distance ranking of fuzzy numbers ,JIEEE Transactions on systems, man and cybernetics –part A. Systems and Humans Vol.30,Nol, 20:76-82.
- [28] Yu-Feng Ho,Hsiao-Lin Wang, Applying Fuzzy Delphi Method to Select the Variables of Sustainable Urban System Dynamics Model.
- [29] Zadeh . L . A (1983) the Role of Fuzzy logic in the management of uncertainty in Expert systems Fuzzy sets and system , 11 , pp 199-227 .

## **AUTHORS**

**THAÏR AHMED SAADOON AL SAMMAN** was born in MOSUL, IRAQ. He received the Bachelor in 1984 degree from the university of MOSUL, IRAQ and the master in year 1987 degree from the university of MOSUL,IRAQ both in business management and the Ph.D. in year 2008 degree from the university of MOSUL,IRAQ .He is currently Ass. Prof. in management information system in the college of Business administration in university of MOSUL. His research interests include operation management and operations research.

