

CONGESTION MANAGEMENT IN DEREGULATED POWER SYSTEM USING FACTS DEVICES

Hiren Patel¹ and Ravikumar Paliwal²

¹P.G.Scholar PIT, GTU, Vadodara, India

²Assistant Professor PIT, GTU, Vadodara, India

ABSTRACT

Congestion management is one of the technical challenges in Power system. In electricity market transmission congestion happens when there is not enough transmission ability to transmit the power without any restrictions for transmission of a line. Flexible different current transmission system (FACTS) devices can be another choice to reduce the flows in heavily loaded lines , resulting in an increased loadability, low system losses, improved of the network, reduced cost of production by controlling the power flow in the network. A method to determine the optimal location of FACTS devices suggested based on the sensitivity analysis. The simulation results were successfully tested on IEEE-30 bus test system in Power World Simulator.

KEYWORDS: Congestion Management, TCSC, UPFC , Power World Simulator.

I. INTRODUCTION

Nowadays, several important issues related to power system have been discussed worldwide. Some of the serious issues are the power quality, transmission loadability, congestion management reduce power losses and voltage stability[2]. To overcome these issues, best approach is using FACTS devices. Congestion management schemes used today have negative impacts on energy markets, such as disruptions and monetary penalties, under some conditions. To mitigate these concerns various congestion management methods have been proposed, including redispatch and curtailment of scheduled energy transmission. In the restructured electric energy industry environment, new congestion management approaches are being developed that strive to achieve the desired degree of reliability while supporting competition in the bulk power market.

This report first presents an overview and background on key issues and emerging approaches to congestion management. One potential option to manage congestion is load curtailment. By reducing the demand from the customers, the power flow in the congested transmission line is reduced. As a result, the congestion of a transmission line is relieved. But, these methods aim at mitigating physical limit violations by using priority system to curtail transmission system. In such situations, a solution is needed to have successful transmission. Second option to manage congestion is to operating FACTS devices on transmission lines. This operation of FACTS devices depends on their location of use. Congestion management considers both technical and economic considerations [4].

In this paper simulation of IEEE-30 bus test system is used as an example to remove the congestion from it. For this 2 FACTS devices TCSC & UPFC are used which can control active power & reactive power. The FACTS devices have location in this simulation as they have minimum total congestion rent and minimum total generation cost.

This paper structured as follow: Section II represent FACTS devices model, Section III shows TCSC modelling, UPFC modelling are represented in section IV, Section V gives best location for TCSC and UPFC placement, Section VI shows Simulation result, Future scope is discussed in section VII.

II. FACTS DEVICES MODEL

The FACTS concept is based on the substantial incorporation of power electronic devices and methods into the high-voltage side of the network, to make it electronically controllable (IEEE / CIGRE, 1995). Many of the ideas upon which the foundation of FACTS rests evolved over a period of many decades. Nevertheless, FACTS, an integrated philosophy, is a novel concept that was brought to fruition during the 1980's at the Electric Power Research Institute (EPRI), the utility arm of North American utilities. FACTS looks at the ways of capitalizing on many breakthroughs taking place in the area of high-voltage and high current power electronics, aiming at increasing the control of power flows in the high voltage side of the network during both steady-state and transient conditions [7]. Power electronic devices have had a revolutionary impact on the electric power systems around the world. The availability and application of Thyristors have resulted in a new breed of Thyristor-based fast operating devices devised to control and switching operations. The below chapter deals with the basic operating principles of FACTS devices and provides detailed discussions about the structure, operation, and modelling of the TCSC and the UPFC.

FACTS controllers can be broadly divided into four categories, which include

- Series controllers
- Shunt controllers
- Combined series-series controllers
- Combined series-shunt controllers.

III. TCSC MODELLING

The basic conceptual TCSC module comprises a series capacitor, C , in parallel with a thyristor-controlled reactor, LS , as shown in Fig.1. However, a practical TCSC module also includes protective equipment normally installed with series capacitors [8]. A metal-oxide varistor (MOV), essentially a nonlinear resistor, is connected across the series capacitor to prevent the occurrence of high-capacitor over-voltages. Not only does the MOV limit the voltage across the capacitor, but it allows the capacitor to remain in circuit even during fault conditions and helps improve the transient stability.

Also installed across the capacitor is a circuit breaker, CB , for controlling its insertion in the line. In addition, the CB bypasses the capacitor if severe fault or equipment-malfunction events occur. A current-limiting inductor, L_d , is incorporated in the circuit to restrict both the magnitude and the frequency of the capacitor current during the capacitor-bypass operation. An actual TCSC system usually comprises a cascaded combination of many such TCSC modules, together with a fixed-series capacitor, CF . This fixed series capacitor is provided primarily to minimize costs.

The model of TCSC is developed to be used for steady state conditions. This device may take a fixed number of discrete values. TCSC are connected in series with the lines. The effect of a TCSC on the network can be seen as a controllable reactance inserted in the related transmission line that compensates reactance of the line. It may have one of the two possible characteristics: capacitive or inductive to decrease or increase the reactance of the line respectively. Their values are functions of the line where the device is located [6]. Moreover, to avoid over compensation of the line, the working range of the TCSC is considered to be $[-0.39X_L, 0.39X_L]$.

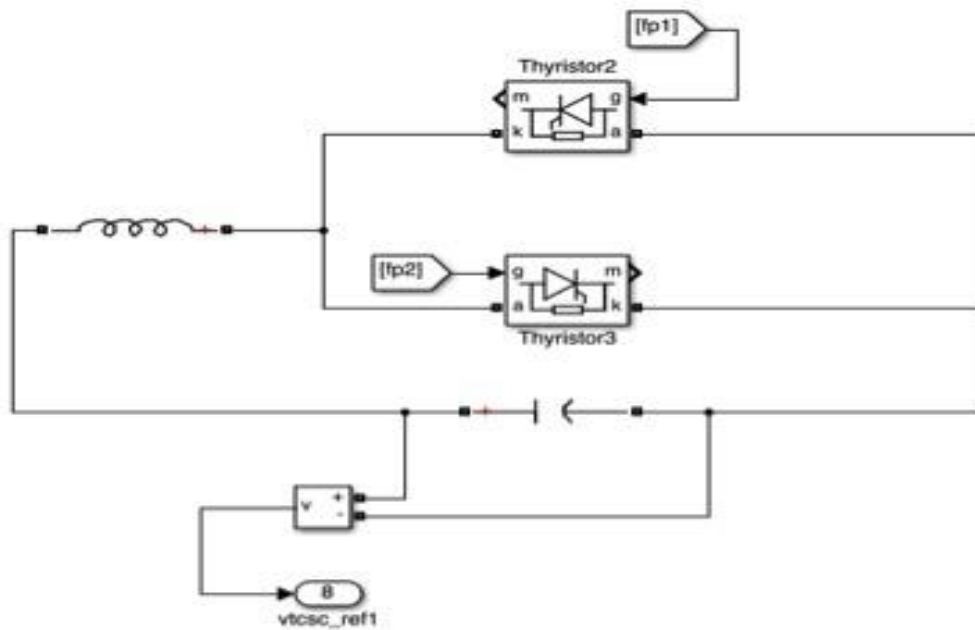

Figure1:- power circuit of TCSC

IV. UPFC MODELLING

The UPFC is the most versatile FACTS controllers with capabilities of voltage regulation, series compensation, and phase shifting. The UPFC is a member of the family of compensators and power flow controllers [8]. The latter utilizes the synchronous voltage source (SVS) concept to provide a unique comprehensive capability for transmission system control. The UPFC is able to control simultaneously or selectively all the parameters affecting the power flow 51 patterns in a transmission network, including voltage magnitudes and phases, and real and reactive powers. These basic capabilities make the UPFC the most powerful device in the present day transmission and control systems.

UPFC fig2.having connected UPFC, the receiving end always injects P_{Bt} - Q_{Bt} to bus j , and sending end voltage maintain V_{Et} in bus i .

According to the above, if UPFC is replaced by elements which are be neutral to the known bus parameters, power flow answers remain constant [8]. These elements should inject P_{Bt} - Q_{Bt} to bus j and keep V_{Et} at bus i . A load model together with a generator is capable of injecting P_{Bt} - Q_{Bt} to bus j while maintaining V_{Et} at bus i . The UPFC Power world simulator model is shown in Fig. 2.

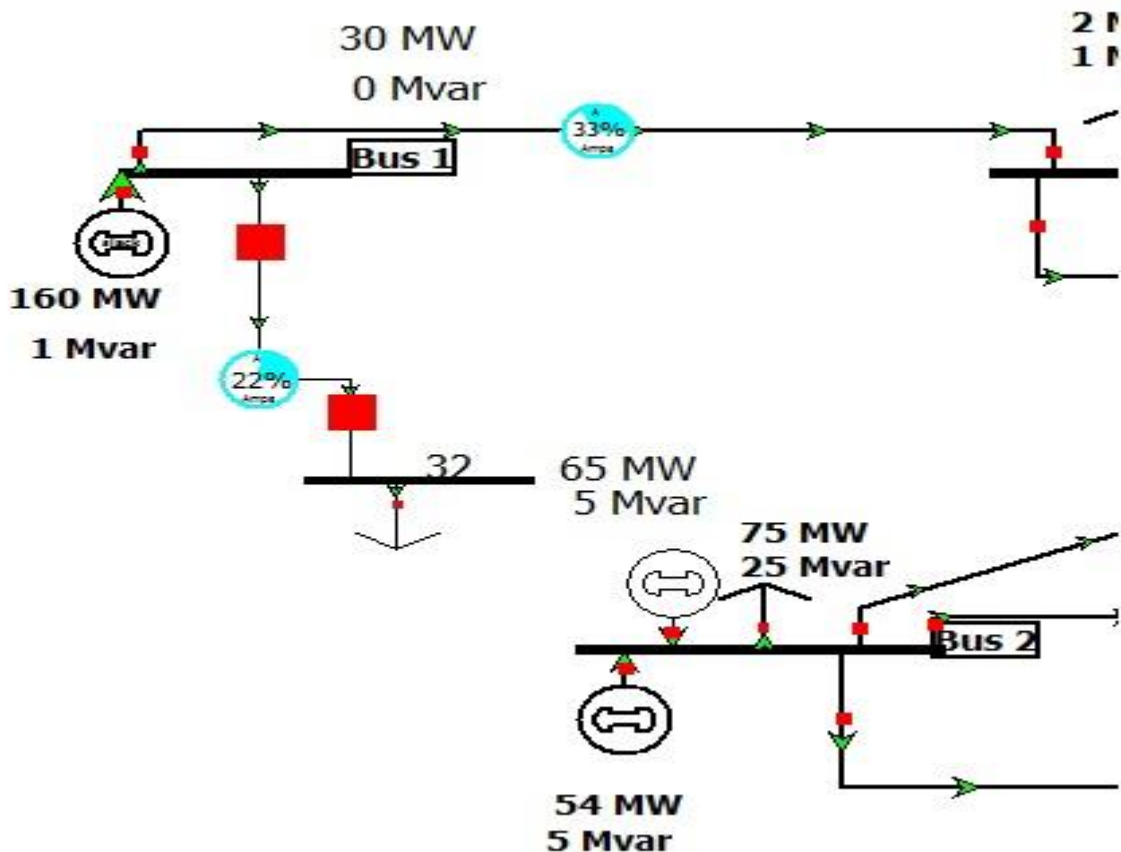

Figure2:- UPFC modelling in Power World Simulator

V. BEST LOCATION FOR TCSC AND UPFC PLACEMENT

To define the appropriate placement of TCSC and UPFC, firstly the base load flow study is carried out for the data. Weak and strong bus are identified with the values of active and reactive power flows respectively. P, Q is computed and ranked. It is noted that TCSC should not be placed between two generator buses. The reason for selecting a 30-bus system is, only a small part of a very large transmission.

VI. SIMULATION RESULTS

A) Without FACTS device

The proposed method has been tested to IEEE 30- Bus System as shown in the Figure3 . Two FACTS devices are inserted in the system in between a bus having low active power flow and a bus having high active power flow comparative results are getting and tabulated with real and reactive power values .

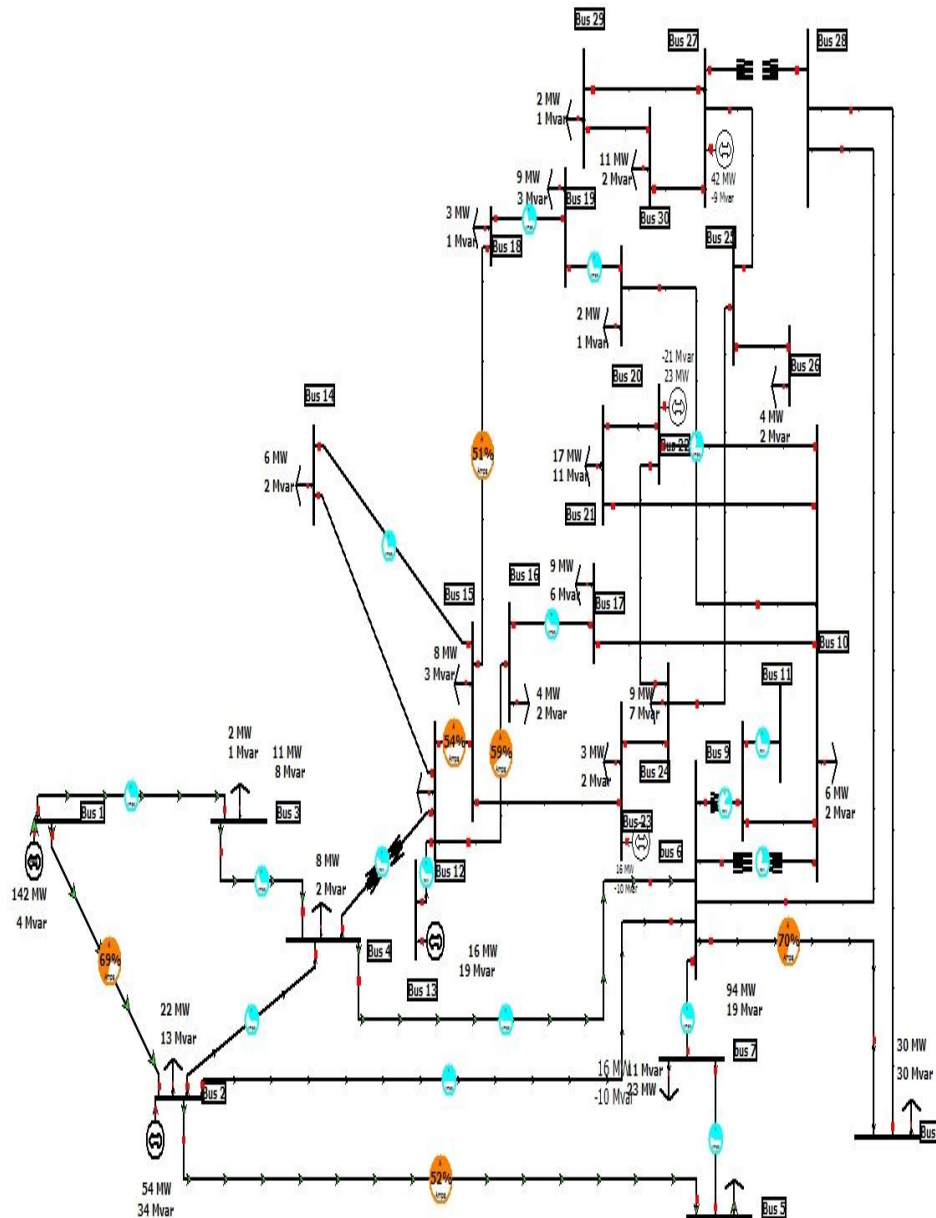

Figure3 :- IEEE-30 bus test system without Congestion

Another shown fig4.shows congestion on line between bus 1 and bus 2. Best location for placement of TCSC and UPFC is on bus 1 and bus 2 as congestion between bus 1 and bus 2 must be gel relieved.

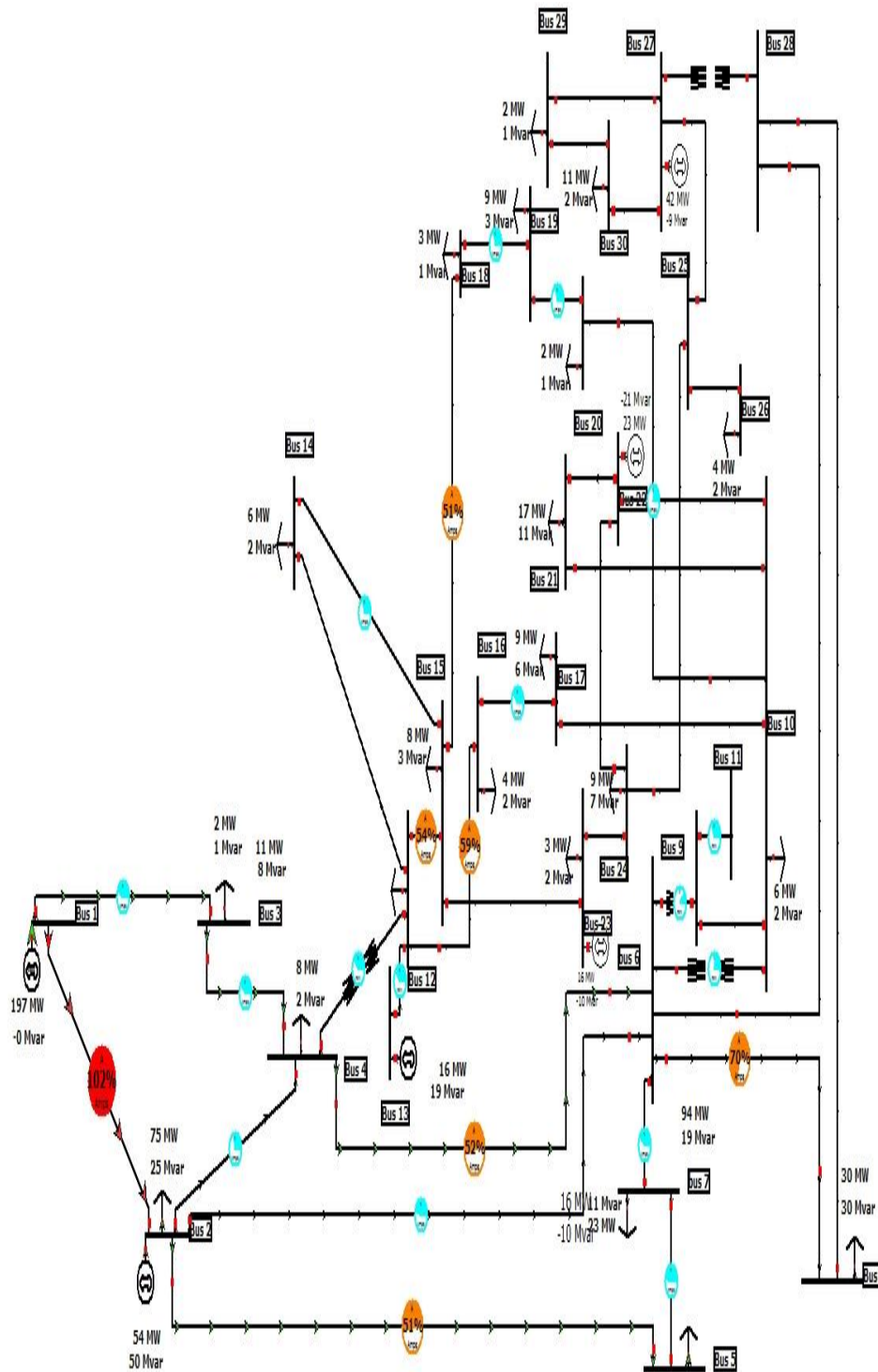

Figure4 :- IEEE-30 bus test system with Congestion

B) With FACTS devices

After connecting TCSC between bus 1 and bus 2 , The following output results indicate the increase in power flows.

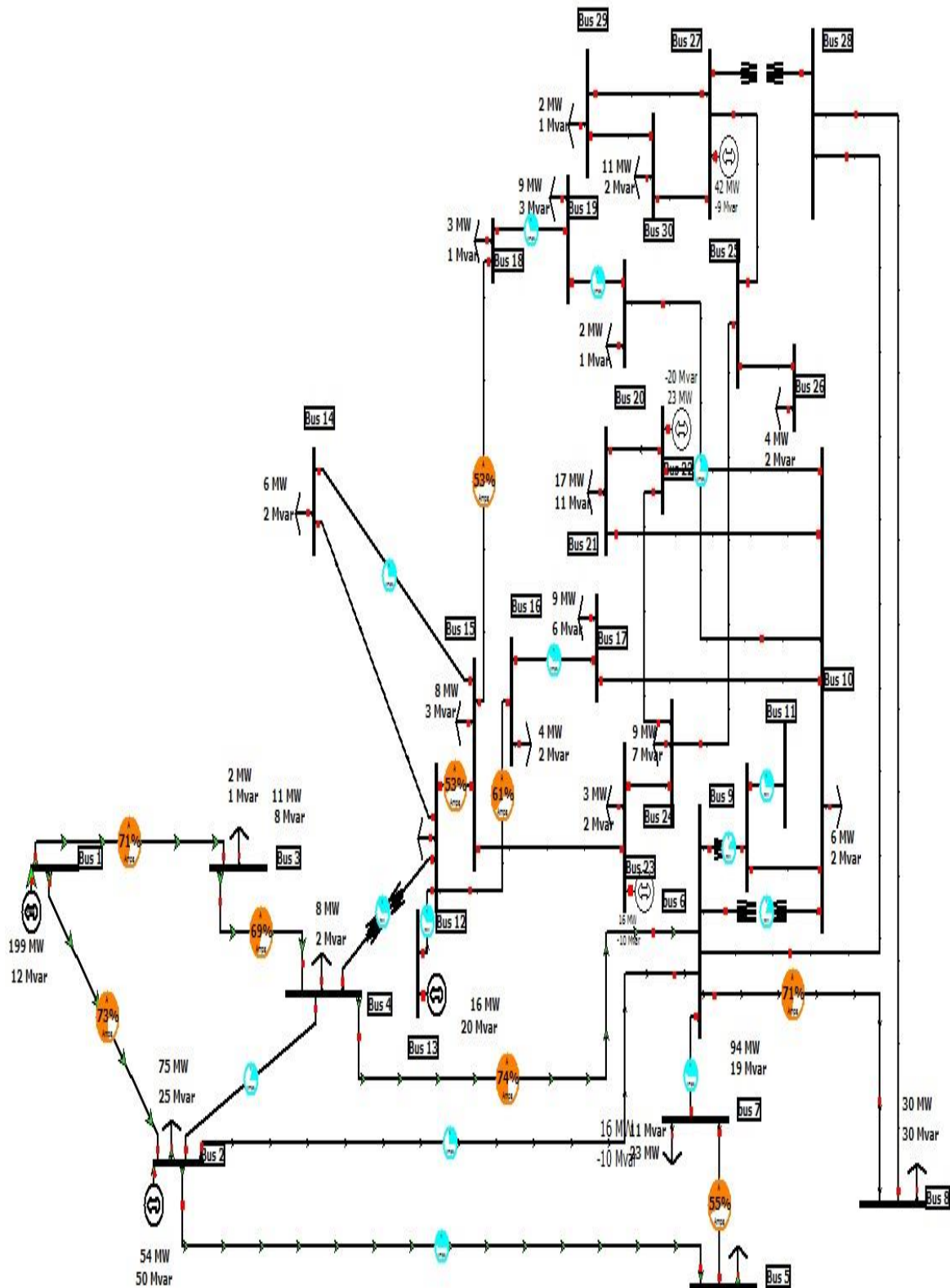

Figure5:-TCSC placed in between Bus 1 and Bus 2 in an IEEE -30 bus congested test system.

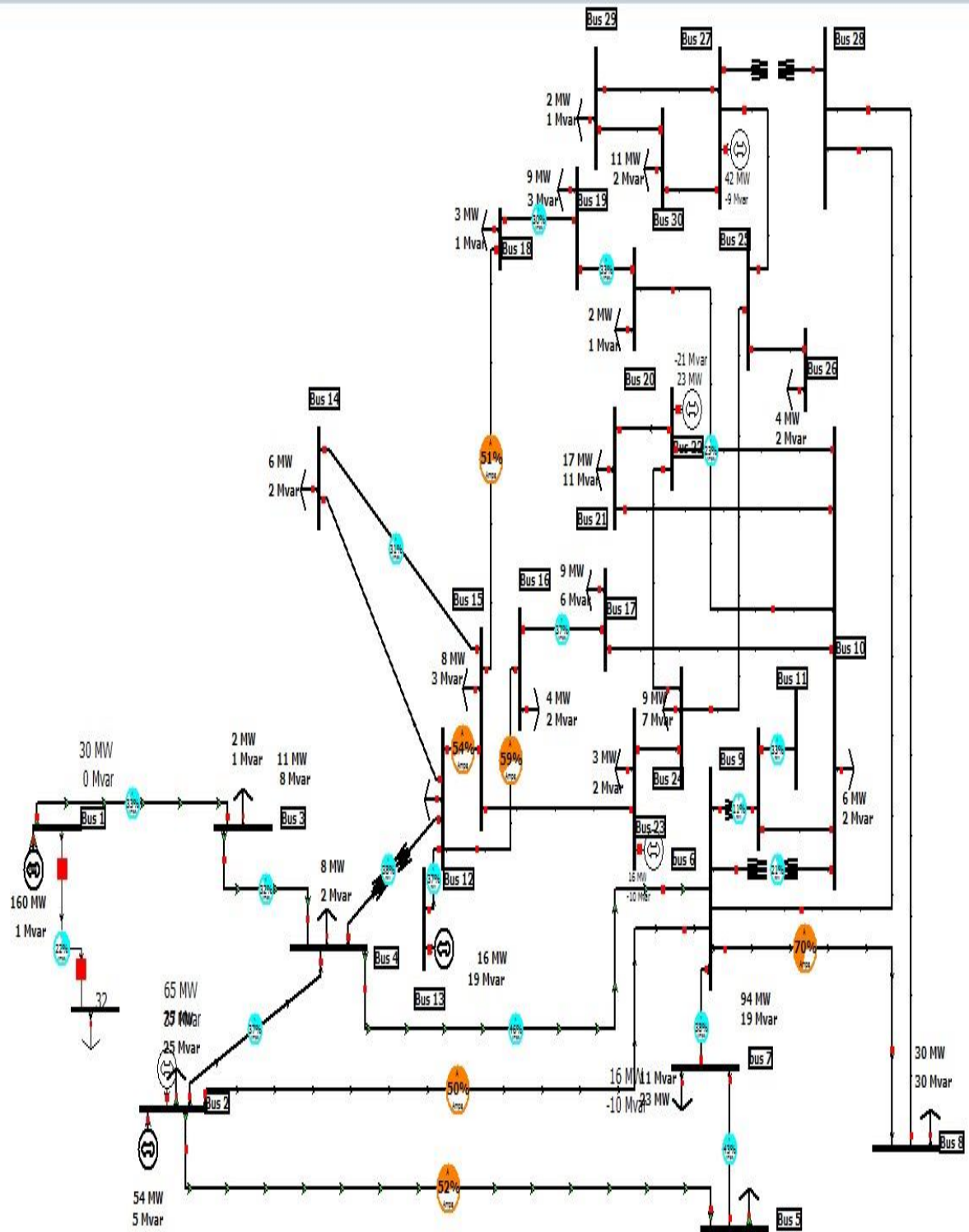

Figure6:-UPFC placed in between Bus 1 and Bus 2 in an IEEE -30 bus congested test system

Results for this system can be shown in a tabulated form on the basis of overloading of transmission lines. We are using IEEE 30 bus test system for system analysis. We will concentrate only on the mainly congested lines. Results of lines loading are compared in given table for 3 conditions.

Table 3: Line loading comparison

Transmission line	Normal Conditions	Congested Conditions	Conditions with TCSC	Conditions with UPFC
1-2	69%	102%	73%	22%(UPFC Joined)
4-6	Under 50%	52%	74%	Under 50%
2-5	Under 50%	52%	Under 50%	52%
6-8	70%	70%	71%	70%

By this table we can see that main purpose of joining TCSC and UPFC (FACTS devices) is getting fulfilled as congestion in mainly congested lines are removed(here line 1-2 was congested).but according to the results UPFC is most effective then TCSC as in results we can see after joining UPFC in line 1-2 all the related lines with it are getting load decrement in them as a benefit of UPFC.

VII. FUTURE SCOPE

We all know that congestion management is mainly based on two things one is Optimal Power Flow and another one is locational Marginal Prices. So we can check generation costs for the same system or another system and can apply another FACTS device to check results for prices as for the different locations and areas. Same test system can be divided into 5-6 areas and generators cost effectiveness can be checked.

For different work process we can check the voltage profile on every bus of the system as it is another benefit of joining the FACTS device in the system. As FACTS devices can improve the Power Quality so we can check the effectiveness of TCSC and UPFC for congestion management as well as for improvement of power quality in the terms of Voltage Profile improvement.

VIII. CONCLUSION

This paper gives a concise idea on each of the FACT devices, UPFC and TCSC. Their Individual contribution towards the improvement of active power flow and reactive power flow and has been tested on a 14-bus system. The TCSC device located at the optimum locations is observed to have a better active power flow improvement than the UPFC. These results are to be further validated by testing it in different power system models. Further the reasons for their [TCSC] performance dominance particularly in active power flow control over UPFC have still to be further investigated.

REFERENCES

- [1] N. Ashokkumar, M. Rathinakumar, M. Yogesh, J. Dinesh, "Comparative Study on the Effectiveness of TCSC and UPFC Facts Controller " IEEE conference, 2013,vol 67- no 5, pp 10-16.
- [2] Liangzhong Yao, Phill Cartwright, Laurent Schmitt, Xiao-Ping Zhang , "Congestion Management of Transmission Systems Using FACTS " IEEE Conference 2005,pp 1-5.
- [3] L. Rajalakshmi, M.V. Suganyadevi, S. Parameswari. " Congestion Management in Deregulated Power System by Locating Series FACTS Devices , IJOCA 2011,vol 13, no 8, pp 19-22.
- [4] RonySeto Wibowo, Naoto Yorino, Mehdi Eghbal, Yoshifumi Zoka, "FACTS Devices Allocation With Control Coordination Considering Congestion Relief and Voltage Stability " IEEE 2011, Vol 26, no 4,pp 2302-2310.
- [5] M. Joorabian ,M. Saniei , H. Sepahvand,"Locating and Parameters Setting of TCSC for Congestion Management in Deregulated Electricity ",IEEE 2011, pp:- 2185-2190.
- [6] Joes H. Vivas, "THE UNIFIED POWER FLOW CONTROLLER: A NEWAPPROACH TO POWER TRANSMISSION CONTROL " IEEE 1995, Vol 10, No 2 pp:- 1085-1097.
- [7]VibhorGupta,"Study and Effects of UPFC and its Control System for Power Flow Control and Voltage Injection in a Power System" IJEST – 2010,Vol 2, pp:-2558-2566.
- [8] Abdel Moamen ,Narayana Prasad Padhy,"Newton-Raphson TCSC Model for Power Flow Solution of Practical Power Networks "IEEE2002, pp:-1488-1493.
- [9] N.Sambasivarao, J.Amrnath, V .Purnachandrarao,"Congestion Management Using Facts Devices In Deregulated Power System " ,IJERT 2013, Vol 2, pp:-90- 95.
- [10] Snehatabude, vedashrerajderkar, " Improvement In Congestion Management With Reduction In Operating Cost In Power System Using STATCOM Controller",IJERT-2013,Vol.2-Issue 5.

- [11] Guguloth Ramesh, T. K. Sunil Kumar, "Congestion Management in a Deregulated Power System with Micro Grid", International Journal of Electrical, Robotics, Electronics and Communications Engineering Vol:7 No:11, 2013
- [12] MANISHA CHADAR ,Thesison "Mitigation of Voltage Sag by Thyristor Controlled Series Capacitor and PWM Generator and their Comparison".
- [13] Mohan mathur, "Thyristor-Based FACTS Controllers and Electrical Transmission Systems" IEEE press.
- [14] K.R.Padiyar, "FACTS Controlles In Power Transmission And Distrubution"
- [15]<http://www.cheers4all.com/2013/09/design-and-simulation-of-thyristor-controlled-series-capacitor>
- [16] <http://faraday1.ucd.ie/psat.html> [14]http://profs.basu.ac.ir/smr_tousi/free_space/psat-2.1.2-ref.pdf

BIOGRAPHY

Hiren I Patel has received B.E. degree from Vadodara institute of engineering & Tech. , Kotambi , Vadodara affiliated to Gujarat Technological University in 2012. Currently he is pursuing his Masters of Engineering in Electrical Engineering with specialization in Power System from the P.I.T, GTU. His research area are basically a Power System congestion management, FACTS and Power Quality Management.



Ravi Kumar has received B.tech from UPTU in 2009. And he has received M.tech from MANIT Bhopal in 2013. Currently he is assistant professor in P.I.T college. And his Research topics are Available Transfer Capability calculation using PTDF, Location of FACTS devices and congestion management

