

RADON TRANSFORM BASED OFDM – IDMA SYSTEM

Dharm Singh Yadav¹, Jaikaran Singh²

¹Research Student, ²Associate Prof.

EC Department SSSIST, Sehore, Bhopal (M.P.)/ RGPV University, India

ABSTRACT

OFDM is a digital modulation scheme in which a wideband signal is split into a number of narrowband signals. Because the symbol duration of a narrowband signal will be larger than that of a wideband signal, the amount of time dispersion caused by multipath delay spread is reduced. The proposed system consists of a novel FRAT (Finite Radon Transform) based model which enables the communication media to scrutiny the noise and also cater for Inter symbol interference also it has been shown that the said system showed good BER performance as compared to other systems, also as the result will show that the ISI reduction is more in our system also the zero padding pose to be a problem which could be rectified in the times to come.

KEYWORDS: OFDM, OFDM-IDMA, FRAT, BER, frame interleave, fast Fourier transform, wavelet transform.

I. INTRODUCTION TO OFDM

Orthogonal frequency-division multiplexing (OFDM) is a method of encoding digital data on multiple carrier frequencies. OFDM has developed into a popular scheme for wideband digital communication, used in applications such as digital television and audio broadcasting, DSL Internet access, wireless networks, power line networks, and 4G mobile communications.

The primary advantage of OFDM over single-carrier schemes is its ability to cope with severe channel conditions (for example, attenuation of high frequencies in a long copper wire, narrowband interference and frequency-selective fading due to multipath) without complex equalization filters. Channel equalization is simplified because OFDM may be viewed as using many slowly modulated narrowband signals rather than one rapidly modulated wideband signal. The low symbol rate makes the use of a guard interval between symbols affordable, making it possible to eliminate inter symbol interference (ISI) and utilize echoes and time-spreading (on analogue TV these are visible as ghosting and blurring, respectively) to achieve a diversity gain, i.e. a signal-to-noise ratio improvement. This mechanism also facilitates the design of single frequency networks (SFNs), where several adjacent transmitters send the same signal simultaneously at the same frequency, as the signals from multiple distant transmitters may be combined constructively, rather than interfering as would typically occur in a traditional single-carrier system.

II. INTRODUCTION TO RADON TRANSFORM

The Radon Transform (RT) was first introduced by Johann Radon (1917) and the theory, basic aspects, and applications of this transform are studied in [4, 7] while the Finite Radon Transform (FRAT) was first studied by [3]. RT is the underlying fundamental concept used for computerized tomography scanning, as well for a wide range of other disciplines, including radar imaging, geophysical imaging, nondestructive testing and medical imaging [11]. Recently FRAT was proposed as a mapping technique in OFDM system [2]. It is found that OFDM based on Haar orthonormal wavelets (DWT-OFDM) are capable of reducing the ISI and ICI, which are caused by the loss in orthogonality between the carriers. The procedure steps of using the Radon based OFDM mapping is as follows:

Step 1: suppose (kd) is the serial data stream to be transmitted using OFDM modulation scheme. Converting) (kd from serial form to parallel form will construct a one dimensional vector containing the data symbols to be transmitted,

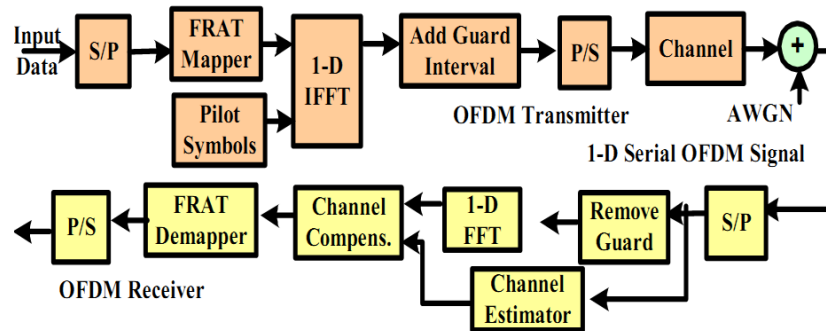

Fig.1 Block Diagram Representation of FRAT based IDMA system

Step 2: convert the data packet represented by the vector $d(k)$ from one-dimensional vector to a $p \times p$ two dimensional matrix $D(K)$, where p should be a prime number according to the matrix resize operation.

Step 3: take the 2-D FFT of the matrix $D(K)$ to obtain the matrix, $F(r, s)$. For simplicity it will be labeled by F .

Step 4: redistribute the elements of the matrix F according to the optimum ordering algorithm given in [17], so, the dimensions of the resultant matrix will be $1(\times pp)$ and will be denoted by the symbol $optF$. The two matrixes for FRAT window= 7 are given by:

$$F = \begin{bmatrix} f_1 & f_8 & f_{15} & f_{22} & f_{29} & f_{36} & f_{43} \\ f_2 & f_9 & f_{16} & f_{23} & f_{30} & f_{37} & f_{44} \\ f_3 & f_{10} & f_{17} & f_{24} & f_{31} & f_{38} & f_{45} \\ f_4 & f_{11} & f_{18} & f_{25} & f_{32} & f_{39} & f_{46} \\ f_5 & f_{12} & f_{19} & f_{26} & f_{33} & f_{40} & f_{47} \\ f_6 & f_{13} & f_{20} & f_{27} & f_{34} & f_{41} & f_{48} \\ f_7 & f_{14} & f_{21} & f_{28} & f_{35} & f_{42} & f_{49} \end{bmatrix}$$

$$F_{opt} = \begin{bmatrix} f_1 & f_1 & f_1 & f_1 & f_1 & f_1 & f_1 & f_1 \\ f_2 & f_{10} & f_9 & f_{16} & f_8 & f_{21} & f_{14} & f_{13} \\ f_3 & f_{19} & f_{17} & f_{31} & f_{15} & f_{34} & f_{20} & f_{18} \\ f_4 & f_{28} & f_{25} & f_{46} & f_{22} & f_{47} & f_{26} & f_{23} \\ f_5 & f_{30} & f_{33} & f_{12} & f_{29} & f_{11} & f_{32} & f_{35} \\ f_6 & f_{39} & f_{41} & f_{27} & f_{36} & f_{24} & f_{38} & f_{40} \\ f_7 & f_{48} & f_{49} & f_{42} & f_{43} & f_{37} & f_{44} & f_{45} \end{bmatrix}$$

Step 5: Take the 1D-IFFT for each column of the matrix $optF$ to obtain the matrix of Radon coefficients, R

Step 6: construct the complex matrix R from the real matrix R

III. MATHEMATICAL EXPLANATION OF RADON TRANSFORM

The radon transform represents an image as a collection of projections along various directions. It is used in areas ranging from seismology to computer vision. The radon function in the Image Processing Toolbox computes *projections* of an image matrix along specified directions. A projection of a two-dimensional function $f(x,y)$ is a line integral in a certain direction. For example, the line integral of $f(x,y)$ in the vertical direction is the projection of $f(x,y)$ onto the x -axis; the line integral in

the horizontal direction is the projection of $f(x,y)$ onto the y -axis. Figure 8-11 shows horizontal and vertical projections for a simple two-dimensional function.

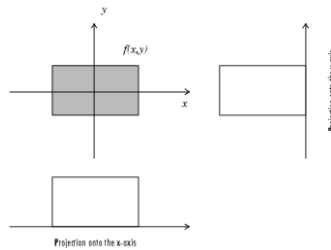

Figure 2: Horizontal and Vertical Projections of a Simple Function

Projections can be computed along any angle θ . In general, the Radon transform of $f(x,y)$ is the line integral of f parallel to the y' axis

$$R_{\theta}(x') = \int_{-\infty}^{\infty} f(x' \cos \theta - y' \sin \theta, x' \sin \theta + y' \cos \theta) dy'$$

where

$$\begin{bmatrix} x' \\ y' \end{bmatrix} = \begin{bmatrix} \cos \theta & \sin \theta \\ -\sin \theta & \cos \theta \end{bmatrix} \begin{bmatrix} x \\ y \end{bmatrix}$$

The figure below illustrates the geometry of the Radon transform.

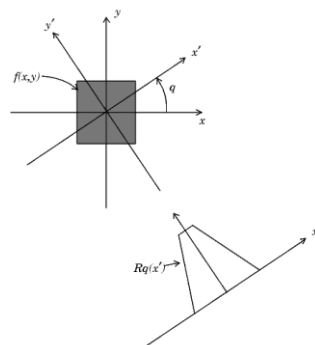

Figure3: The Geometry of the Radon Transform

IV. BASIC PRINCIPLE OF IDMA

Fig. 4 illustrates the use of IDMA in the downlink case, in which UE1 and UE2 are respectively served by NodeB1 and NodeB2 but allocated the same time-frequency resource (chunk). Suppose NodeB1 interleaves the signal for UE1 with interleaving pattern1, while NodeB2 interleaves the signal for UE2 with interleaving pattern2 (different from pattern1), then UE1 (UE2) may distinguish the signals from the two NodeBs by means of different interleavers. In case of using the single-cell receiver, the interference from the other NodeB will be whitened to a noise. In case of employing iterative multi-cell receiver, the interference could be effectively cancelled. Note that IDMA can be employed not only between neighboring NodeBs, but also potentially between neighboring sectors. Similarly, IDMA can also be employed in uplink, as shown in Fig. 2. Two UEs from two neighboring cells can share the same chunk, but interleave their signals with distinct interleaving patterns.

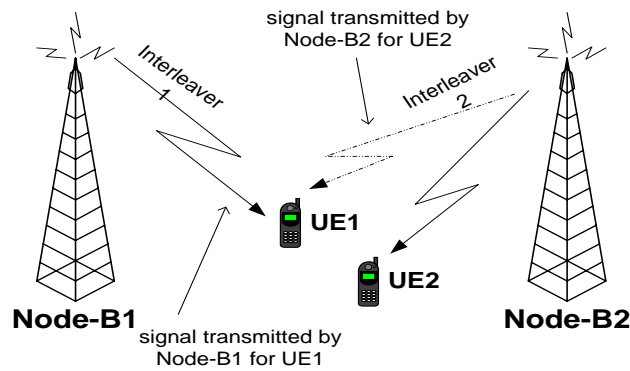

Fig.4 using IDMA in downlink to suppress inter-cell interference

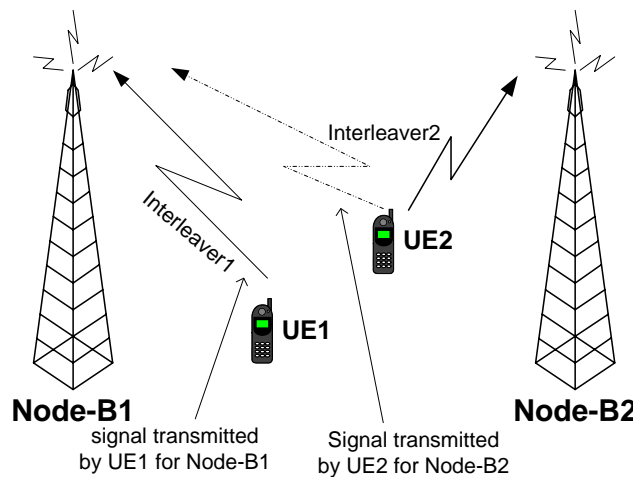

Fig.5 using IDMA in uplink to suppress inter-cell interference

The principle of iterative multi-user (here “user” could be a NodeB, a sector or a UE) detection has been well introduced recently. In the single-user detection, the interference is treated as noise. However, the multi-user detection also demodulate the interfering signal, and improve the detection of the wanted signal. Especially, the iterative multi-user detection is regarded as an attractive technique because it can continuously improve the receiver performance with increasing number of iterations.

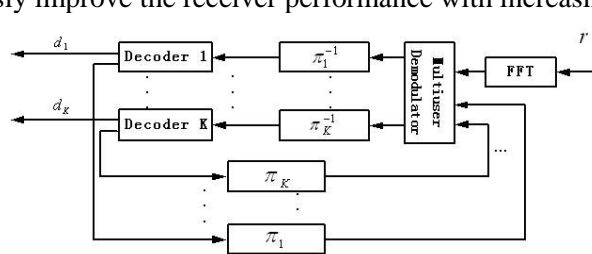

Fig. 6 Structure of iterative multi-user receiver

V. PROPOSED SYSTEM

We have built a graphical user interface using graphical user interface development environment (GUIDE) of Matlab version 11. The GUI helps us in getting results for various configurations quickly. The complete snapshot for our GUI is as given below :-



Fig. 7 Complete Graphical User interface of the project

5.1 Primary Components of the GUI

Below is a complete description of the various components used in the making of graphical user interface :-

- 1) **Data points menu:** - this menu allows the user to select the preliminary data points for the analog signal. Then the generate button generates the waveforms for the selected data points for OFDM-FFT , OFDM-DWT and OFDM-FRAT respectively .. This allows the user to flexibly select any number of points for the analog value and thus keeping the interface as simple as possible.

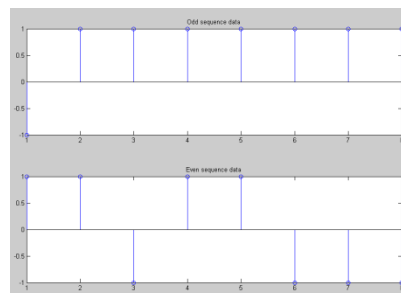

Fig. 8 n=16 sequence of odd and even data points

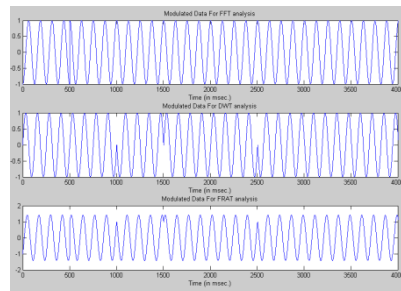

Fig.9 n=16 various waveforms

- 2) **No. of bits to be transmitted :-** This block helps the user to decide the no of digital bits to be transmitted through the channel , hence this blocks helps the user in deciding the max data rate for the simulation , with the help of this block we can simulate OFDM-IDMA for all the three cases at different bit rates.
- 3) **No. of zeros to be padded :-** without zero padding it is not possible to create a OFDM-IDMA system , hence this blocks allows the user to select the no of zeros for the system to be padded in the data stream.

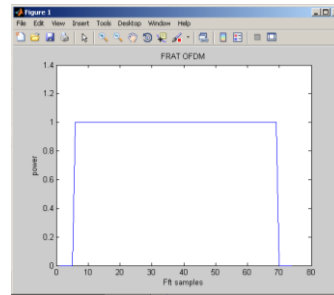

Fig. 10 FRAT OFDM power spectrum for $N=64$, $N_z=10$

- 4) **Compare button :-** With the help of this button simulation and comparative analysis for bit error rate v/s SNR is carried out for all the three cases namely , OFDM-IDMA with FFT , OFDM-IDMA with DWT and OFDM-IDMA with FRAT . The bit rate rate is selected in the menu given above the button.

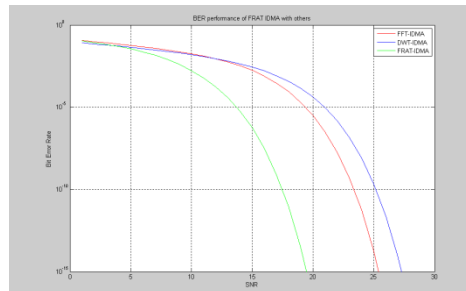

Fig. 11 BER v/s SNR for $N=64$

VI. CONCLUSION

Thus as seen in the above figures that for majority of the test scenarios FRAT-IDMA is showing better performance than traditional IDMA as well as DWT-IDMA , although it is worth noting that such a system has not yet been realized physically and hence it is still a theoretical model and cannot be implemented till date , also as we can see in the diagram for lower data rates , the FRAT system is not been able to compete with the traditional system , but for rest of the cases , FRAT system excels over other systems.

REFERENCES

- [1] Al-Dhahir N. and Cioffi J. "Optimum Finite-Length Equalization for multicarrier Transceivers," Computer Journal of IEEE Transactions communications, vol. 44, no. 1, pp. 56-64, 1996.
- [2] Al-Jawhar W., Kattoush A., Abbas S., and Shaheen A., "A High Speed High Performance Parallel Radon Based OFDM Transceiver Design and Simulation," Computer Journal of Digital Signal Processing, vol. 18, no. 11, pp. 907-918, 2008.
- [3] Beylkin G., "Discrete Radon Transforms," Computer Journal of IEEE Transactions Acoustic, Speech, and Signal Processing, vol. 35, no. 2, pp. 162-172, 1987.
- [4] Bolker D., "The Finite Radon Transform," Integral Geometry and Contemporary Mathematics, vol. 63, no. 2, pp. 27-50, 1987.
- [5] Burrus S., Gopinath R., and Guo H., Introduction to Wavelets and Wavelet Transforms: A Primer, Prentice Hall, 1998.
- [6] Cimini L., "Analysis and Simulation of a Digital Mobile Channel Using Orthogonal Frequency Division Multiplexing," Computer Journal of IEEE Transactions on Communication, vol. 33, no. 3, pp. 665-675, 1985.
- [7] Deans R., The Radon Transform and Some of its Applications, John Wiley and Sons, 1983.
- [8] Graps A., "An Introduction to Wavelets," Computer Journal of IEEE Computational Science and Engineering, vol. 2, no. 2, pp. 50-61, 1995.
- [9] Goswami C. and Chan K., Fundamentals of Wavelets Theory, Algorithms, and Applications, John Wiley and Sons Ltd, 1999.

- [10] IEEE Std., IEEE Proposal for 802.16.3, RM Wavelet Based PHY Proposal for 802.16.3, Rainmaker Technologies, 2001.
- [11] Koffman I. and Roman V., "Broadband Wireless Access Solutions Based on OFDM Access in IEEE 802.16," IEEE Communication Magazine, vol. 40, no. 4, pp. 96-103, 2002.
- [12] Lawrey E., "The Suitability of OFDM as a Modulation Technique for Wireless Telecommunications, with a CDMA Comparison," Thesis James Cook University, 1997.
- [13] Lee I., Chow J., and Cioffi J., "Performance Evaluation of a Fast Computation Algorithm for the DMT in High-Speed Subscriber Loop," Computer Journal of IEEE Select Areas Communication, vol. 13, no. 9, pp. 1564-1570, 2007.
- [14] Lindsey R., "Wavelet Packet Modulation for Orthogonally Multiplexed Communication," Computer Journal of IEEE Transactions Signal Process, vol. 45, no. 5, pp. 1336-1337, 1997.
- [15] Mallat S., A Wavelet Tour of Signal Processing, Academic Press, 1999.
- [16] Mallat S., "A Theory for Multiresolution Signal Decomposition: the Wavelet Representation," Computer Journal of IEEE Pattern Analysis and Machine Intelligence, vol. 11, no. 7, pp. 674-693, 1989.
- [17] Minh N. and Martin V., "The Finite Ridgelet Transform for Image Representation," Computer Journal of IEEE Transactions Image Processing, vol. 12, no. 1, pp. 16-28, 2003.
- [18] Mohammed J., "VIDEO Image Compression Based on Multiwavelets Transform," PhD Thesis, University of Baghdad, 2004.
- [19] Nee V. and Prasad R., OFDM for Wireless Multimedia Communications, Artech House, 2000.
- [20] Nghi H., Ha H., and Le-Ngoc T., "Bit-Interleaved Coded OFDM with Signal Space Diversity: Subcarrier Grouping and Rotation Matrix Design," Computer Journal of IEEE Transactions on Signal Processing, vol. 55, no. 3, pp. 1137-1149, 2007.

AUTHORS BIOGRAPHY

Dharm Singh Yadav –I am a research students of SSSIST Sehore, Bhopal affiliated to RGPV Bhopal. I have received his B.Tech degree from UCER Naini Allahabad in 2005. For 5 years I worked in Suryaamba Spinning Mills Ltd. Nagpur as a Technical Manager in Engineering and Research Department. From 2010 to 2012, I was an Assistant professor at Electronics and Communication Engineering Department at Prasad Group of Institutions Jaunpur, U.P.

