

## DESIGNING BLADES FOR HORIZONTAL-AXIS WIND TURBINES APPLIED TO MICRO ENERGY

Oliveira, Mariana Schmidt<sup>1</sup>, Cândido, Luis Henrique Alves<sup>2</sup>

<sup>1</sup>Graduate Program in Design, Laboratory of Design and Material Selection, Federal University of Rio Grande do Sul, UFRGS, Av. Osvaldo Aranha, 99 - sala 604 - Centro Histórico, Porto Alegre, Brazil.

<sup>2</sup>Departament of Design and Graphic Expression, Laboratory of Design and Material Selection, Federal University of Rio Grande do Sul, UFRGS, Av. Osvaldo Aranha, 99 - sala 604 - Centro Histórico, Porto Alegre, Brazil.

### ABSTRACT

*Electricity generation through small wind turbines is gaining worldwide popularity. However, studies that describe and analyze this source of energy are still scarce compared to those that analyze the medium and large wind turbines. Therefore, the present study aimed to analyze the National Advisory Committee for Aeronautics (NACA) blade profile considering its design adequacy to be applied to the design of the small horizontal-axis wind turbine blades. The number of rotation per minute (RPM) of the 3 blade profiles was based on the design of NACA 0012, 1412, 6409 profiles. These blades were submitted to wind tunnel test with wind velocity of 1m/s to 5m/s. Three pitch angles (15°, 30° e 45°) were used for each blade profile. The results showed that the NACA 1412 blade profile had a lower starting time in m/s compared to that of the NACA 6409 and NACA 0012. Therefore, we suggest the NACA 1412 as the most suitable profile to be applied in low wind speed and to be used in urban architectural structures.*

**KEYWORDS:** SMALL WIND TURBINES, WIND TURBINES, BLADES, NACA.

### I. INTRODUCTION

Today, 54% of the global population lives in cities and by 2050, 66% of the world's population is projected to be urban [1]. In Brazil, in 2010, the urbanization rate reached 84% and is expected to reach 90% by the year 2020, causing great social, environmental and economic impact. Cities need to create sustainable alternatives and solutions while respecting the natural limits of the ecosystem. Action plans for science, technology and innovation (STI) are essential to face the main challenges of making cities more sustainable. One of the solutions to achieve that is the use of renewable energy, including wind power [1].

There are two basic types of wind turbines: horizontal axis wind turbines (HAWT) and vertical axis wind turbines (VAWT). Wind turbines are classified according to their size and power: large, medium, small, very small, and micro generator). However, there are several approaches on how to classify the wind turbines according to these two features. The National Electric Energy Agency (ANEEL), according to the normative resolution 482 of April 17, 2012, lays down the general conditions for access of micro generation with power of up to 100 kW and mini distributed generation above 100 kW and up to 1 MW (solar power systems and other renewable energy generators) connected to the electricity distribution system [2,3].

The wind turbine blades are the components that come into direct contact with the mass of air in motion, transmitting kinetic energy to the blades. The blade design is developed to maximize the transfer of energy and turn a possible significant amount into electric power. Several variables are present when determining geometry which requires controlled behavior during the contact with the fluid, for example: wind velocity energy production for a specific distribution of wind; maximum power limit; resist loads inherent to the object; resonances; weight and cost. Of these variables, the present study focused on the

relationship of the blade geometry with the wind velocity which the micro generator is submitted to, seeking to know and to measure the factors that can make an impact on the efficiency of the small size wind turbines [4].

Aerodynamically, the HAWTs are more efficient and operate with greater rotation than the VAWTs. In a study on the implementation of an energy conversion system suitable for urban use suggested that HAWT was the most adequate for this particular case [5]. The HAWT with three blades have relatively smooth and stable movements, with less noise pollution, visual impact, and very little vibration [2].

Emphasis was placed on the following aspects of the application of small and very small generators: safety (to prevent blade detachment or the fall of a turbine from the top of the building); easy operation, mounting and maintenance; lower noise level, (lower than that produced by the motor vehicles and wind in the trees surrounding the area); and installation (according to health and safety standards and regulations to prevent damage to the building structure by vibration and high-performance, due to lower wind speed found in urban environments) [5].

There is a wide range of aerodynamic profiles that are used in wind turbines, among these, the family of NACA (National Advisory Committee for Aeronautics), RISØ (RisØ National Laboratory), FFA (The Aeronautical Research Institute of Sweden) and NREL (National Renewable Energy Laboratory) [6, 7].

The digits in NACA's four digit numbering system are defined as follows: the first digit denotes the maximum camber as a percent of the chord; the second digit denotes the chordwise position of the maximum camber in tenths of the chord; the last two digits denotes the maximum thickness of the airfoil section as a percent of the chord. An aerofoil that is not cambered is called a symmetrical aerofoil, in contrast to a nonsymmetrical aerofoil [8].

The design of wind turbine blades, also called airfoils, should consider two significant aspects: structure and aerodynamics. Some phases of the design process regarding the aerodynamics are as follows: determination of the airfoil geometry, the aerodynamic parameters (pitch angle and speed), and the geometry of the longitudinal profile of the blade (chord and twisting) [4]. Figure 1 illustrates the speeds and forces acting on a wind turbine blade. Although the angle of attack has a direct influence on the aerodynamic forces, it is more convenient to express the power developed by it according to the pitch angle ( $\beta$ ), whose measurements and controls are simpler [9].

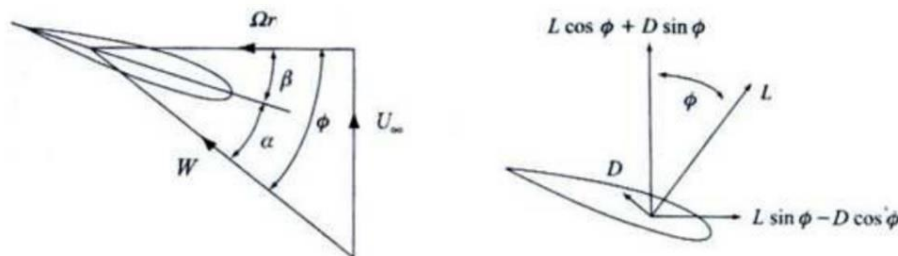

- $\phi$  = Inflow angle [°]
- $\alpha$  = Angle of attack [°]
- $\beta$  = Pitch angle [°]
- $W$  = Relative Wind speed [m/s]
- $U$  = Wind speed [m/s]
- $\omega r$  = Rotational speed [m/s]
- $L$  = Lift force [N]
- $D$  = Drag force [N]

**Figure 1.** Speeds and forces acting on the wind turbine blade [9]

The wind speed ( $U$ ) acts on the system and interacts with the rotational speed ( $\omega r$ ), forming the resulting speed ( $W$ ). Angle of attack ( $\alpha$ ) is the angle between the airfoil chord line and the relative air flow. The pitch of a wind-turbine blade ( $\beta$ ) describes the angle of the blade chord to the plane of rotation. Lift ( $L$ ) is defined as the component of the total aerodynamic force perpendicular to the flow direction, and drag ( $D$ ) is the component parallel to the flow direction [10].

The main aerodynamic characteristics of a profile include the lift coefficient, the drag coefficient and efficiency.

Lift is the component of aerodynamic force perpendicular to the relative wind. Drag is the component of aerodynamic force parallel to the relative wind. Lift coefficient ( $C_l$ ) is the ability of the airfoils to lift when exposed to any force act upon it, and is an important factor for the efficiency of the profile [11] It is associated with the profile model, the Reynolds number ( $Re$ ) and the angle of attack and represents the profile efficiency to generate lift forces. Profiles with high lift coefficient values are more efficient to generate lift. Drag Coefficient ( $C_d$ ) represents the potential of a profile to generate drag force. Considering that a higher lift coefficient is required for a profile to be considered efficient, a lower drag coefficient should be obtained. A profile is aerodynamically efficient when it generates a maximum lift coefficient combined with low drag coefficients. For a profile, the drag coefficient is also a function of the Reynolds number and the angle of attack. Therefore, the higher the resulting value of the lift coefficient divided by the drag coefficient, the more aerodynamically efficient is the profile. These coefficients are usually measured in a wind tunnel or with the use of aerodynamic simulation software. The behavior of the air flow around airfoils according to the angle of attack ( $\alpha$ ) can be divided into three operational zones: at  $15^\circ$  the lift is nearly linear; between  $15$  and  $30^\circ$ , power loss occurs; and between  $30^\circ$  and  $90^\circ$ , it stalls [8].

Few studies have been conducted on the small scale wind turbines (SSWTs) especially for the applications near ground level where wind speed is of order of few meters per second [12]. Kishore, Coudron and Priya [12] conducted a study on a small horizontal axis 3-blade wind turbine portable generator for residential rooftop with winds of up to 5 m/s. The NACA 0012 airfoil was used as it apparently works best at lower Reynolds numbers. This airfoil is often analyzed for multiple applications in several studies, including those carried out by Ahmed et al [13]; Alam et al [14]; Laitone [15]; Vardar and Alibas [16].

It is important that small wind turbine rotors have a good start - up response to low wind speeds (rpm) [12]. Based on the studies by Kishore, Coudron and Priya [12], a wind tunnel for testing of aerodynamic efficiency and a computer program for turbine test (SolidWorks) were used for the development of the wind turbine. The main design specifications of the blade were determined as follows: the blade chord, the hub, the blade length were 7.5 cm, 3cm, and 20 cm, respectively. Its blades were linearly twisted by  $32^\circ$  from root to tip.

The turbine starts spinning with 2.7 m/s and can produce maximum power output of 0.83 W when the wind speed is 5 m/s. It can generate enough power to charge batteries of some electronic devices, such as mobile phones, and small radio sets.

Some studies have described different blade shapes for large and medium-sized wind generators. However, studies focused mostly on the performance of blades for wind micro generators are scarce. Moreover, the models and the optimized operating conditions proposed for large-scale turbines cannot be directly applied to small-scale turbines due to their relatively different aerodynamic behavior [17]. Therefore, the present study aimed to integrate the NACA profiles for use in micro turbines by suggesting the most suitable pitch angle.

The structure of the article is given as follows: the *Introduction* which describes important aspects for a better understanding of the study as well as the state of the art of the proposed topic; Section II describes the *Materials and Methods* used to obtain the number of rpms for each NACA profile. Section III contains the *Results and Discussion*, and finally, Section IV, *Conclusions* with suggestions for future work.

## II. MATERIALS AND METHODS

This was an experimental, quantitative descriptive study. The flow chart below shows the basic methodology sequence applied in this study.

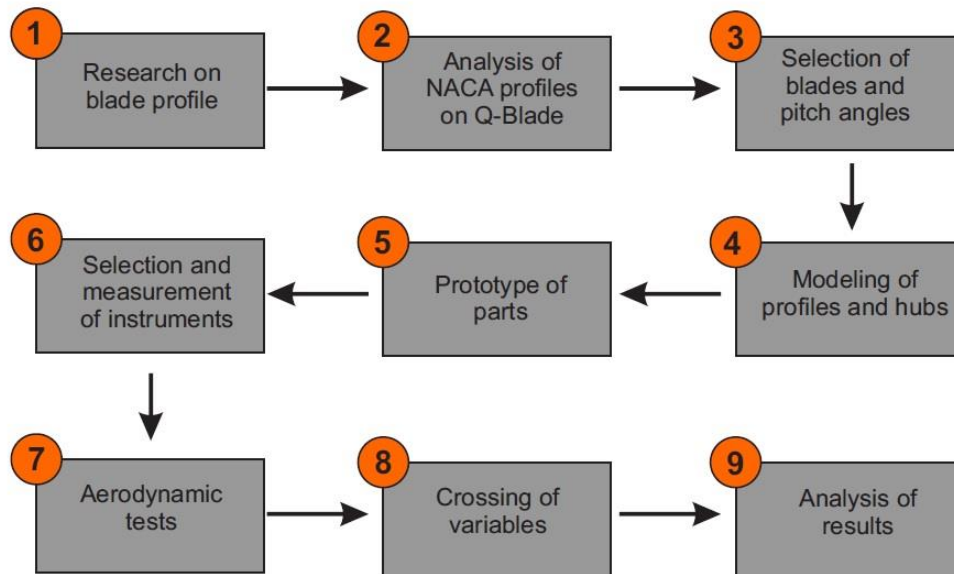

**Figure 2.** Flow chart of methodology used in this study

Figure 2 shows nine steps for developing the present study: (1) Research on the profile of wind power generators; (2) analysis of the NACA 4-digit searched in the database of the Airfoil Tools, with Q-Blade; (3) selection of blades and pitch angles; (4) modeling of profiles and hubs using the Inventor, a 3D modeling software; (5) prototyping of turbine blades and hubs with different pitch angles, using FDM 3D printer; (6) selection and measurement of the instruments used; (7) aerodynamic tests in the wind tunnel; (8) organization and analysis of data obtained by crossing variables; and (9) analysis of results.

For the simulation of the selected NACA models, we used QBlade, which is an open source wind turbine calculation software developed by the Institute of Fluid Dynamics and Technical Acoustics, former Hermann-Föttinger-Institut, Technische Universität Berlin (TU Berlin). With the QBlade, the NACA four-digit models were selected in the database of the Airfoil Tools from University of Illinois at Urbana-Champaign. Thus, it was possible to verify the relationship between the lift coefficient ( $C_l$ ) and the drag coefficient ( $C_d$ ) of the selected models, as displayed in Table 1.

**Table 1:** Characteristics of NACA profiles

NACA profile	$C_l / C_d$	Reynold	Angle of attack
0006	60.3	1000000	5.75
0008	69.9	1000000	7.5
0009	75.6	1000000	7.25
0010	74.1	1000000	9
0012	62	1000000	9.25
0015	77.9	1000000	9
0018	77.9	1000000	10
0021	74.7	1000000	8.5
0024	68.8	1000000	9
1408	77.2	1000000	7
1410	78.9	1000000	3.5
1412	83.8	1000000	5
2408	86.8	1000000	2,5
2410	98.5	1000000	3.75

2411	113.7	1000000	4
2412	101.4	1000000	4.5
2414	103.7	1000000	5
2415	102.2	1000000	5.75
2418	97.1	1000000	7
2421	89.5	1000000	7.5
2424	65.9	1000000	7.25
4412	129.4	1000000	5,25
4415	119.4	1000000	5.5
4418	115.8	1000000	5.75
4421	103.1	1000000	5.75
4424	73.6	1000000	7.75
6409	151	1000000	5
6412	142.7	1000000	5.75

Table 1 shows the NACA 0012, 1412 and 6409 profiles selected in order to verify the RPM values and the significant differences between them for a wind turbine microgenerator. Three pitch angles were used (15°, 30° and 45°). For each NACA profile, nine combinations of wind speeds (1, 2, 3, 4 and 5 m/s) were performed.

The blades were 24 mm wide (chord) and 67 mm high and were built layer-by-layer from the bottom up using a 3D printer that runs on FDM Technology (Fused Deposition Modeling). Figure 3 shows the design of components.

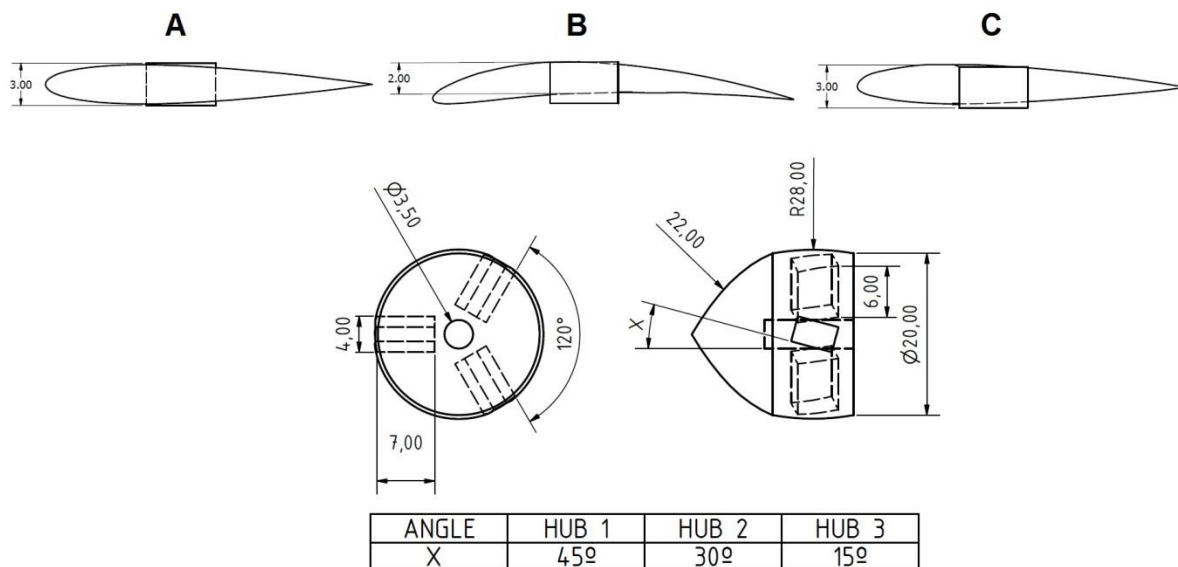
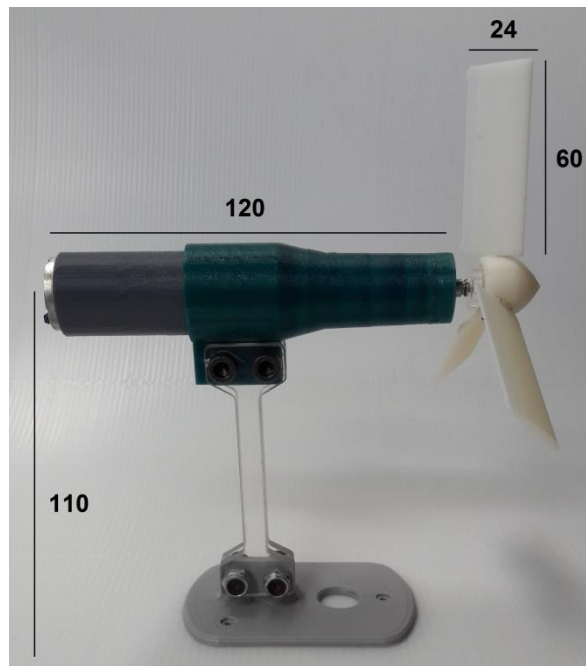

Figure 3. Design of airfoil components

Air foil profiles of NACA 0012, 6409, and 1412 are shown in letters A, B and C, respectively. Angle "x" represents the twist lengthwise of the cavity positioning the blades. Hub 1 has the "x" angle in 45°; hub 2 has the x angle in 30°; and hub 3, the x angle in 15°. Figure 4 shows the micro turbine blades mounted in a hub.



**Figure 4.** Wind power micro-generator prototype

The wind tunnel was used for aerodynamic tests to estimate the efficiency of the wind blades. The wind tunnel was 2.020 mm long and 525 mm high. The internal frame was 386 mm wide and 400 mm long. Dynamic drag of the tunnel is achieved with the use of a fan that generates an air flow from outside to inside the tunnel. The wind tunnel dynamics is reversed so that a 250 mm fan draws the wind into the tunnel. The wind passes through the anemometer (1) hitting the specimen (2) that is placed 550 mm from the anemometer (Figure 5).

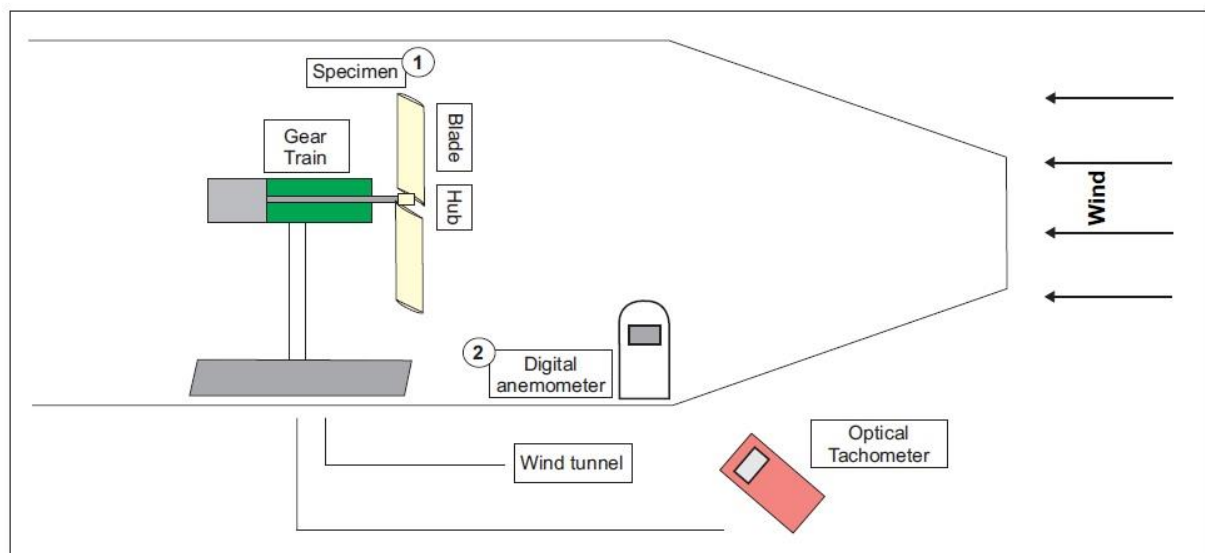

**Figure 5.** Schematic diagram of the wind-tunnel experimental setup

For the present study, wind speeds were measured with a portable digital anemometer (Incoterm). The equipment also provides air temperature, however this variable was not analyzed. The anemometer was positioned in the wind tunnel entrance, using a support designed specifically for this purpose. The instrument calibration was performed at the Laboratory of Design and Material Selection, Federal University of Rio Grande do Sul (LMF /UFRGS).

A digital, battery-powered portable non-contact optical tachometer (red LED), model TD-812 of Intrutherm was used. This device operates using a LED light source, with a resolution of 0.1 RPM and accuracy of  $\pm 0.05\%$  or  $\pm 1$  Digit. The tachometer has a measurement range of 500 mm to 2000 mm. This device is aimed at the spinning target to which a piece reflective tape has been affixed. As the light source hits the target it is reflected off the tape and back to the tachometer. For the analysis of the models of blades studied and tested in the wind tunnel, the laser beam focused on a piece of reflective tape applied to turbine hubs.

### III. RESULTS AND DISCUSSION

The results revealed that all the profiles tested showed higher rpm values at  $45^\circ$  pitch angle, followed by  $30^\circ$  and  $15^\circ$ , because there was greater contact area of the blade in relation to the direction of the wind.

At a  $45^\circ$  pitch angle, the NACA 6409 profile obtained greater rpm values followed by NACA 0012 and 1412. At a  $30^\circ$  pitch angle, the NACA 6409 profile had also greater rpm values, followed by NACA1412 and 0012 profiles. Regarding the  $15^\circ$  pitch angle, the NACA 6409 profile obtained greater rpm values, followed by the NACA 0012 and 1412 profiles; the profile order that showed higher and lower values of rpm was similar to those for the  $30^\circ$  pitch angle. The rpm values obtained for the NACA 0012 and 1412 profiles were quite similar compared with those of the NACA 6409 profile; however, when applying the values for a larger rotation rate per hour, a more significant difference was observed. The RPM data are displayed in Table 3.

Table 2. Comparative values obtained

M/S	Values obtained (RPM)								
	PITCH ANGLE $45^\circ$			PITCH ANGLE $30^\circ$			PITCH ANGLE $15^\circ$		
	NACA 1412	NACA 6409	NACA 0012	NACA 1412	NACA 6409	NACA 0012	NACA 1412	NACA 6409	NACA 0012
1	147.33	251.66	220.33	27.77	77.77	72.10	47.66	-	29.77
2	265.55	333.44	291.88	108.44	123.33	110.10	71.33	55.10	73.66
3	464.21	541.33	493.44	234.99	238.33	228.55	77.77	113.44	111.44
4	646.77	726.99	653.11	346.11	368.66	341.44	127.77	154.10	165.33
5	838.77	913	870.33	463.99	497.66	425.22	161.33	243.77	210.99

It should be pointed out that the combination that obtained greater rpm values was the NACA 6409 profile with a pitch angle of  $45^\circ$ , the maximum air velocity value was 913 rpm at a wind speed of 5 m/s. The second higher rpm was 870.33 generated by the NACA 0012 profile, at a  $45^\circ$  pitch angle. The third larger rpm was to 838.77 obtained by the NACA 1412 profile with a similar pitch angle. Therefore, the NACA 6409 profile generated 1.05 times more rpm than the NACA 0012 profile, and 1.08 times more rpm compared with the NACA 1412 profile at a  $45^\circ$  pitch angle and at a wind speed of 5 m/s.

For the comparison of pitch angles, the NACA 6409 profile had a rpm value 1.83 times higher at a  $45^\circ$  pitch angle with wind speed of 5 m/s than at a  $30^\circ$  pitch angle, and 3.74 times higher than at a  $15^\circ$  pitch angle.

For similar speed, the NACA 0012 profile had rpm value 2.05 times higher at a  $45^\circ$  angle compared with a  $30^\circ$  angle and 4.14 times at a  $15^\circ$  pitch angle. Additionally, the NACA profile 1412 had a rpm value 1.81 times higher at a  $45^\circ$  angle compared with a  $30^\circ$  pitch angle, and 5.2 times more compared with a  $15^\circ$  pitch angle. The results obtained showed that the NACA 1412 profile had more significant differences in rpm when the pitch angle was changed, while the NACA 6409 profile showed less significant differences.

Graph 1 clearly shows the direct relationships generated by NACA profiles tested and referred to in the Table 1.



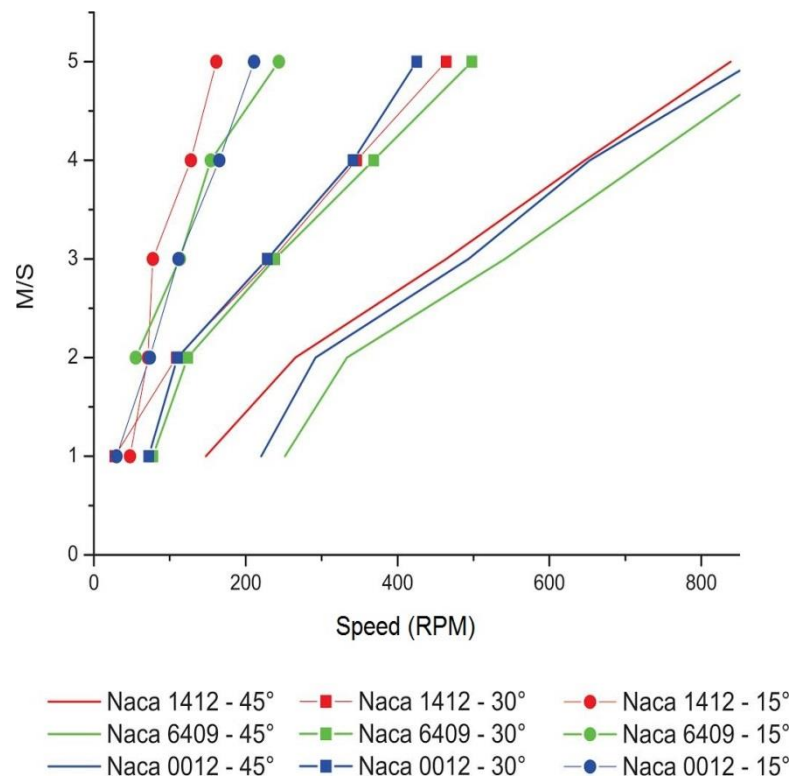

Figure 6. Comparative values obtained

In graph 1, the lower rpm value for 1 m/s was displayed by the NACA 6409 profile at a pitch angle of 15° (0 m/s), since the start up response of this profile at this pitch angle was 2 m/s. The second lower rpm value (27.77) was obtained by the NACA 1412 profile at a 30° pitch angle. The third lower rpm value (29.77) was achieved by NACA 0012 profile at a 15° pitch angle. The results showed that the NACA 6409 profile presented the higher rpm value for 5 m/s at a 45° degree pitch angle and lower rpm value at wind speed of 1 m/s, at a 15° pitch angle. However, the NACA 6409 profile at a 45° pitch angle presented 251.66 rpm, the higher rpm compared to all values obtained at wind speed of 1 m/s. Still under the influence of 1 m/s, the NACA 0012 profile had the second higher value of rpm (220.33) at a 45° pitch angle and the NACA 1412 profile had the third higher value (147.33 rpm) at a 45° pitch angle. The NACA 6409 profile at a 15° pitch angle showed the lower rpm with 1 m/s, considering that the start-up response of this profile at that particular pitch angle was 2 m/s. However, the same profile presented greater rpm value with 5 m/s at a 45° pitch with 913 rpm. The rpm values for the NACA 0012 and NACA 1412 profiles were quite similar. This can be justified by the fact that both profiles presented relatively similar  $cl/cd$  relationship when compared with the NACA 6409 profile.

The selected wind turbine of the NACA 6409 profile at a 45° pitch angle started spinning with 1.6 m/s, at a 30° pitch angle with 1.6 m/s, and at a 15° pitch angle with 2.0 m/s. The NACA 0012 profile at a 45° pitch angle started spinning with 1.6 m/s, at a 30° pitch angle with 1.6 m/s, and at a 15° pitch angle with wind speed of 1.3 m/s. Finally, the NACA 1412 profile at a 45° pitch angle started spinning at wind speed of 1.2 m/s, at a 30° pitch angle with 1.3 m/s, and at 15° pitch angle at wind speed of 1.0 m/s.

According to Kishore, Coudron and Priya [12], the rpm values as well as the start-up response of the blade are quite significant for a small-sized wind turbine, although they do not represent the generation of higher power of a blade since they are not directly related to torque.

#### IV. CONCLUSION AND FUTURE WORK

The NACA 6409 profile with a pitch angle of 45° presented 913 rpm, rotating at the highest RPMs. This profile showed the highest number of RPMs for all pitch angles, which can be explained by the fact that it has the highest  $cl/cd$  ratios.



The NACA profiles tested showed higher rpm values at 45° pitch angle and pitch angles between 30° and 15° when a larger contact area of the blade with the direction of the wind at 45° was observed i.e. the lower wind speed at which the blades were submitted, the lower the rpm differences at different pitch angles. However, significant differences were verified when the blades were submitted to higher wind speeds. The rpm differences between the NACA profiles at 15° and 30° pitch angles were lower than those found between the 30° and 45° pitch angles.

Based on the results obtained, the NACA 1412 profile had lower start-up response in m/s compared with the NACA 6409 profile and the NACA 0012 profile. Therefore, the NACA 1412 is the most suitable profile to be applied with low wind speed and to be used in urban architectural structures.

Suggestions for future work:

- To analyze other NACA profiles.
- To measure the aerodynamic efficiency of selected profiles.
- To estimate the amount of energy generated in each situation exposed in the present study.
- To investigate the various possible applications of small farm wind turbines.
- To investigate suitable materials for the production of small farm wind turbines.

## **ACKNOWLEDGEMENTS**

The authors would like to thank the Laboratory of Design and Material Selection, the Federal University of Rio Grande do Sul-UFRGS, and the Coordination for the Improvement of Higher Education Personnel (CAPES) or financial and technical support.

## **REFERENCES**

- [1] Cagnin C., Fraga R., Vilela B. Estratégia de Ação para o tema Cidades Sustentáveis: significados e implicações para a política nacional de ciência e tecnologia. Brasília: Centro de Gestão e Estudos Estratégicos. 2015.
- [2] Custódio, R. S. Energia Eólica para Produção de Energia Elétrica. Rio de Janeiro: Eletrobrás, 2013.
- [3] Tibola, G. Sistema eólica de pequeno porte para geração de energia elétrica com rastreamento de máxima potência. Dissertação (Mestrado em Engenharia Elétrica) - Universidade Federal de Santa Catarina, Florianópolis, 2009.
- [4] Pires, J. C; Oliveira, B. F. Modelagem e Simulação Virtual de Pá para Aerogerador de Pequeno Porte. Design & Tecnologia. 2010.
- [5] Wenzel, G. M. Projeto aerodinâmico de pás de turbinas eólicas de eixo horizontal. 2007. Monografia (Graduação em Engenharia Mecânica) - Pontifícia Universidade Católica do Rio Grande do Sul, Porto Alegre, 2007.
- [6] Santos, A. A. Projeto de geração de energia eólica. 2006. Monografia (Graduação em Engenharia Industrial Mecânica). Universidade de Santa Cecília. 2006.
- [7] Henn, E. Máquinas de Fluido. 2. ed. Santa Maria: Ed. da UFSM, 2006.
- [8] Junior, A.G.A. Estudo sobre o modelamento de um aerofólio NACA 0012. Monografia (Graduação em Engenharia Industrial Mecânica). Universidade Estadual de Campinas. 2012.
- [9] Rocha, Rafael Vieira. Simulação de aerogerador em uma bancada experimental. 2008. Dissertação (Mestrado em Engenharia Elétrica) – Universidade Federal do Rio de Janeiro, Rio de Janeiro, 2008.
- [10] Silva, E. R. R.G. Projeto de uma Turbina Eólica de Eixo Horizontal. Projeto de Graduação apresentado ao Curso de Engenharia Mecânica da Escola Politécnica, Universidade Federal do Rio de Janeiro. 2013.
- [11] Melo, T. Energia Eólica: Fundamentos e cenário do crescimento no Brasil e no Mundo, 2010.
- [12] Kishore R.A, Priya S. Design and experimental verification of a high efficiency small wind energy portable turbine (SWEPT). J. Wind Eng.Ind.Aerodyn. Journal of Wind Engineering and Industrial Aerodynamics. 2013.
- [13] Ahmed, N., Yilbas, B.S., Budair, M.O. Computational study into the flow field developed around a cascade of NACA 0012 airfoils. Computer Methods in Applied Mechanics and Engineering. 1998.
- [14] Alam, M., Zhou, Y., Yang, H., Guo, H., MI, J. Theultra- Low Reynolds number airfoil wake. Experiments in Fluids. 2010.
- [15] Laitone, E.V. Wind tunnel tests of wings at Reynolds numbers below 70000. Experiments in Fluids. 1997.
- [16] Vardar, A.; Alibas I. Research on wind turbine rotor models using NACA profiles. Department of Agricultural Machinery, Faculty of Agriculture, Uludag University, Bursa, Turkey Received. Renewable Energy Journal. 2007.
- [17] - Epaarachchi, J. A., Clausen, P. D., The development of a fatigue loading spectrum for small wind turbine blade. Journal of Wind Engineering and Industrial Aerodynamics. 2006.

## AUTHORS

**Oliveira, Mariana Schmidt.** Holds degree in Design – UniRitter Laureate International Universities. Masters student in Design, Graduate program in Design, Laboratory of Design and Material Selection, Federal University of Rio Grande do Sul, Porto Alegre, Brazil. Under the guidance of Prof. Dr. Luis Henrique Alves Cândido.



**Cândido, Luis Henrique Alves,** holds degree in Industrial Design (Product Design), Master and Doctorate degrees in Material Science and Technology from the PPGE3M/UFRGS Program. Adjunct Professor of product design (DEG/FA/UFRGS), Professor of the Graduate program in Design (PgDesign/UFRGS).

