

# NUMERICAL STUDIES OF FLOW THROUGH ANNULAR CURVED DIFFUSER

P. K. Sinha<sup>1</sup> and B. Majumdar<sup>2</sup>

<sup>1</sup>Department of Mechanical Engineering, DIATM, Durgapur-713212, India

<sup>2</sup>Department of Power Engineering, Jadavpur University, Kolkata, India

## ABSTRACT

*In the present investigation the distribution of mean velocity, static pressure and total pressure are experimentally studied on an annular curved diffuser of 37.5° angle of turn with an area ratio of 1.284 and centerline length was chosen as three times of inlet diameter. The experimental results then were numerically validated with the help of Fluent and then a series of parametric investigations are conducted with same centre line length and inlet diameter but with different area ratios varying from 1.15 to 3.75.*

*The measurements were taken at Reynolds number  $2.15 \times 10^5$  based on inlet diameter and mass average inlet velocity. Predicted results of coefficient of mass averaged static pressure recovery (31%) and coefficient of mass averaged total pressure loss (21%) are in good agreement with the experimental results of coefficient of mass averaged static pressure recovery (27%) and coefficient of mass averaged total pressure loss (17%) respectively. Standard  $k-\epsilon$  model in Fluent solver was chosen for validation. From the parametric investigation it is observed that static pressure recovery increases up to an area ratio of 2.86 and between the area ration 2.86 to 3.75, pressure recovery decreases steadily. The coefficient of total pressure loss almost remains constant with the change in area ratio for similar inlet conditions.*

## KEYWORDS

*Annular curved diffuser,  $k-\epsilon$  model, Fluent solver, Five-hole probe.*

## NOMENCLATURE

$A_r$	Area ratio	D	Inlet diameter of the Diffuser
$A_s$	Aspect ratio	L	Centerline length of the Diffuser
CC	Concave or outward wall	Re	Reynolds number
$C_{PR}$	Coefficient of pressure recovery	$\Delta \beta$	Angle of turn of the center line
CV	Convex or inward wall		

## 1. INTRODUCTION

Diffusers are used in many engineering application to decelerate the flow or to convert the dynamic pressure into static pressure. Depending on application, they have been designed in many different shapes and sizes. The annular curved diffuser is one of such design and is an essential component in many fluid handling systems. Annular diffusers are an integral component of the gas turbine engines of high-speed aircraft. It facilitates effective operation of the combustor by reducing the total pressure loss. The performance characteristics of these diffusers depend on their geometry and the inlet conditions. Part turn or curved diffusers are used in wind tunnels, compressor crossover, air conditioning and ventilation ducting systems, plumes, draft tubes, etc.

The objective of the present study is to investigate the flow characteristics within a circular cross sectioned annular curved diffuser. The performance of an annular curved diffuser is characterizes by static pressure recovery and total pressure loss coefficient.

Surveying of the reported literatures on various types of diffusers reveals that the studies on straight diffusers are available in considerable numbers in open literatures but literatures for curved diffusers, specially, part turn diffusers are less in number and detailed flow measurements methodologies for these diffusers are very limited in the open literatures.

The first systematic studies on 2-D curved subsonic diffusers were carried out by Fox & Kline [1]. The centerline of the diffuser was taken as circular with a linearly varying area distribution normal to the centerline. They established a complete map of flow over a range of the  $L/D$  ratio and at different values of  $\Delta\beta$ . Seddon [2] has made extensive experimental investigations to explain the self-generated swirl within the S-shaped diffuser of rectangular to circular cross-section having  $A_r = 1.338$ . He observed a significant improvement in the performance and exit flow distribution by introducing fences of 10 different configurations within the first bend of the diffuser.

In the early parts of 1980's researchers started working on how to improve the performance by introducing vortex generator, fences etc. within the diffusers to change the magnitude and direction of the generated secondary motion.

Vakili *et al.* [3] reported the experimental studies in an S-shaped diffusing duct of  $\Delta\beta = 30^\circ/30^\circ$  having circular cross-section and  $A_r = 1.5$ . They observed that there is a significant improvement in the exit flow distribution and pressure recovery by introducing vortex generator at the inlet. Yaras [4] experimentally investigated the flow characteristics of  $90^\circ$  curved diffuser with strong curvature having  $A_r = 3.42$  for different values of inlet boundary layer thickness and turbulence intensity. Measurements were taken by the help of seven-hole pressure probe. He observed that the performance parameters were almost independent by the variations in the inlet boundary layer. Reichert and Wendt [5] experimentally studied the effect of vortex on the flow field of a diffusing S-duct with  $\Delta\beta = 30^\circ/30^\circ$  and  $A_r = 1.5$ . The objective was to reduce flow distortion and improve total pressure recovery within the diffuser by using the vortex generation at the inlet. They concluded that the mechanism responsible for improved aerodynamic performance is not boundary layer re-energization from shed axial vortices but rather the suppression of detrimental secondary flows by redirecting the flow. Majumder *et al.* [6] also studied the performance characteristics of a  $90^\circ/90^\circ$  S-shaped diffuser of rectangular cross section with  $A_r = 2.0$  and inlet  $A_s = 6.0$  by using three-hole pressure probe. They observed a detached flow at the inflexion point and overall pressure recovery in comparison to a straight diffuser is low. Sonoda *et al.* [7] studied the flow characteristics within an annular S-shaped duct. They observed that the total pressure loss near the hub is larger due to the instability of the flow, as compared with that near the casing, in the case of curved annular downstream passage. The total pressure loss near the hub is greatly increased compared with the straight annular passage.

Mullick and Majumdar [8] studied the performance of a fully developed subsonic turbulent flow in  $22.5^\circ/22.5^\circ$  circular cross section S-shaped diffusing duct. The experiment was carried out with  $Re = 8.4 \times 10^5$  and measurements were taken with the help of a pre-calibrated five-hole pressure probe. The experimental results indicated the generation of secondary flow in the form of a pair of contra rotating vortices in the first half, which changes its senses of rotation in the second half and overall static pressure recovery was 40%. Numerical Simulation of flow development through turbine diffusers was reported by Dominy *et al.* [9]. They performed the experiment in an S-shaped annular duct with  $A_r = 1.5$  with inlet  $Re = 3.9 \times 10^5$ . They used 34 numbers inlet swirl vanes. The results show that the influence of wakes and swirl upon the flow has a significant effect upon the development of flow. The numerical simulations also give a good matching of the flow development within this diffuser. Fuji *et al.* [10] studied the Curved Diffusing Annulus Turbulent Boundary layer Development and concluded a simplified but reliable method for boundary layer calculation with acceptable assumptions for special flow situations. A numerical and experimental investigation of turbulent flows occurring in a  $180^\circ$  bend annular diffuser with an aperture in front of the bend was reported by Xia *et al.* [11]. They observed that the pressure recovery coefficient increases with increasing blow of mass flow rate and inlet pressure but remains nearly constant if the inlet pressure is higher than about 10 bars. The numerical prediction is compared with the experimental data and excellent agreement is achieved.

Singh *et al.* [12] conducted investigation to select the range of the inlet swirl intensity for the best performance of annular diffusers with different geometries but having the same equivalent cone angle. This is analyzed on the basis of the static pressure recovery and total pressure loss coefficients. The results show that the parallel diverging hub and casing annular diffuser produces the best performance at high-swirl intensities

## 2. EXPERIMENTAL FACILITY

A test rig for the present investigation has been constructed at Fluid Mechanics & Machinery Laboratory of Power Engineering Department Jadavpur University to investigate the flow characteristics within a circular cross sectioned annular curved diffuser. The geometry of the test diffuser is shown in Fig. 1. with co-ordinate system and measurement locations. The entire set up was fabricated from mild steel sheet except the test diffuser.

The test diffuser was designed with increase in area from inlet to exit and it distributed normal to the centerline as suggested by Fox and Kline [1]. The test diffuser was designed based on an area ratio of 1.284 and centerline length of 225 mm. The test diffuser is made of fiber glass reinforcement plastic. Centerline was turned at  $37.5^\circ$  from inlet to exit with inlet diameter of 78 mm.

In order to avoid the pressure losses and flow distortion at the inlet and exit, two constant area connectors were attached at the inlet and exit of the test diffuser. A pre-calibrated five-hole pressure probe was used to obtain detailed flow parameters like mean velocity and its components, total and static pressure and secondary motions along the entire length of the diffuser. Ambient air was used as working fluid.

For measuring mean velocity and its components and static and total pressure surveys along the entire cross section of curved diffuser, the test piece was divided into four plane, the Inlet section one diameter upstream of the test diffuser, two planes, Section A and Section B at  $12.5^\circ$  and  $25^\circ$  turn along the length of the diffusing passages and the fourth plane, Section C is at the mid point of the exit duct. The details of measured planes are shown in Fig. 1. For measurement of flow parameters the five hole pressure probe was inserted through a 8 mm drilled hole provided at eight locations, namely,  $0^\circ$ ,  $45^\circ$ ,  $90^\circ$ ,  $135^\circ$ ,  $180^\circ$ ,  $225^\circ$ ,  $270^\circ$  and  $315^\circ$  angle as shown detail in Fig.1.

The pre-calibrated five hole pressure probes was mounted in a traversing mechanism and the probe inserted into the flow field through 8 mm diameter drilled hole provided at the wall. The probe was placed within 1 mm of solid surface for the first reading. The probe was then moved radially and placed at the desired location as shown in Fig. 1.

Instrumentation for the present study was chosen such that the experimental errors are minimum and also to have quick response to the flow parameters.

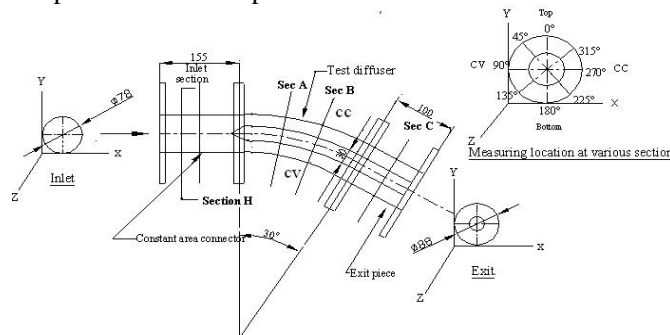

FIGURE 1. Geometry of test diffuser and measuring locations

The pre-calibrated hemispherical tip five-hole pressure probe used for the present study. The probe was calibrated and using non null technique was used to measure the flow parameter. All the five sensing ports of the probe were connected to a variable inclined multi tube manometer. The readings were recorded with respect to atmospheric pressure. The mean velocity and components of mean velocity distribution have been drawn with the help of SURFER software. The assessment of errors resulting from the readings of the present five hole pressure probe was made as a function of all incidence angles for all flow characteristics in all the probe sectors and discussed in details [13, 14].

## 3. RESULTS AND DISCUSSIONS

The flow characteristics have been evaluated by mass average mean velocity, between the curved walls, total pressure and static pressure of the flow at various cross sections. Measured flow quantities

have been presented in the form of 2-D profiles. All the velocities and pressures were normalized with respect to the inlet mass average velocity and inlet dynamic pressure respectively.

### 3.1 Mean velocity contour

The normalized mean velocity distribution in the form of contour plots at various sections of the curved diffuser has been discussed here and is shown in Fig.2. Mean velocity at Inlet Section as shown in Figure 2(a) indicates that the flow is symmetrical in nature throughout the entire cross-sectional area. The high velocity fluid occupies most of the cross-section except close to the bottom surface indicating no upstream effect on the flow due to the presence of the hub.

Figure 2(b), of Section A of the annular curved diffuser depicts that the flow is better distributed though the high velocity core is located along the top portion of the plane. Further Fig. 2(b) indicates the overall acceleration of flow compared to the inlet as the effective flow of velocity is reduced due to the insertion of the hub. The mean velocity distribution in Section B is shown in Fig. 2(c). This figure shows that the overall diffusion takes place at this section compared to the previous section. It is also observed that the more or less uniform flow occupies most of the cross-sectional area. The curvature effect has more reduced due to the presence of the hub, which restricts the movement of the bulk of the flow to one side of the diffuser. This phenomenon indicates the restriction of the development of the counter rotating flows between the top and bottom surface mainly due to presence of the hub and hence a better uniform flow is seen. However along the central plane of the Section B diffusion is not much and flow is more or less symmetrical in nature. However, the contour line at the bottom surface indicates the generation of secondary motion, which is limited to this only.

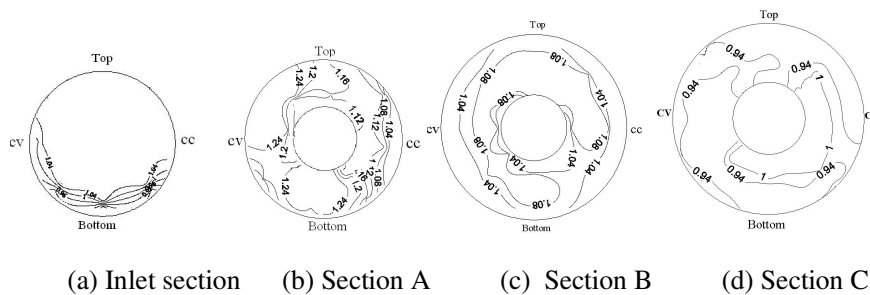

FIGURE 2. Mean velocity Contour

The velocity distribution at Section C as shown in Fig. 2(d) clearly indicates the further diffusion of flow along the centerline of the flow passage due to increase in cross sectional area. The figure also depicts that the high velocity core is shifted a little towards concave wall though the diffused uniform flow has occupied the more or less the whole cross sectional area. The secondary motion, which observed at previous sections, is not clearly seen at this section indicating a better flow at the exit of the annular curved diffuser.

### 3.2 Pressure Recovery & loss Coefficient

The variation of normalized mass averaged static pressure recovery and total pressure loss coefficients based on the mass average pressure at different sections of the test diffuser are shown in Fig.3. It was calculated based on the static pressure difference between the succeeding and preceding sections. The figure shows that the coefficient of pressure recovery decreases steadily up to the Section A in annular curved diffuser and then the increase takes place in rapidly up to the Section C. This is mainly due to the formation of secondary motions The overall mass average pressure recovery coefficient is nearly 27% for this diffuser.

The mass average total pressure loss coefficient decreases in steadily in the test diffuser up to the Section A. Then the loss coefficients in curved diffuser increases sharply up to Section-C. The overall mean value in mass average pressure loss coefficient is nearly 17 % for this test diffuser.

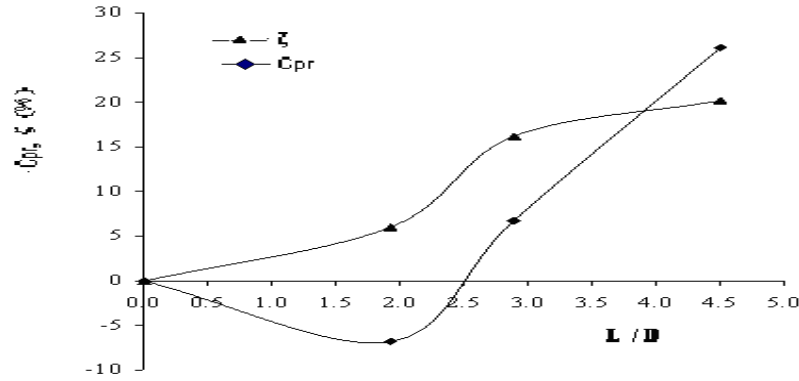

FIGURE 3. Variation of mass average pressure recovery and loss coefficients

### 3.3 Numerical Validation

In the present study a preliminary investigation was carried out using different turbulence models available in FLUENT. Based on the Intensive investigation it was found that Standard k-ε model of turbulence provides the best result and results obtained from computational analysis match both in qualitatively and quantitatively with the experimental results. It is to be noted here that the inlet profiles obtained during experiment are fed as an inlet condition during the validation with FLUENT. Some of the validation figures are shown in Fig. 4(a), Fig. 4(b) and Fig. 4(c) respectively.

All three figures indicate that the mass averaged mean velocity contours obtained by computational and experimental investigations, which shows a qualitative matching to each other. The mean velocity distribution at the Section B and Section C are shown in Fig. 4(b) and Fig. 4(c) show a reasonably good agreement of the computational investigation with the experimental results.

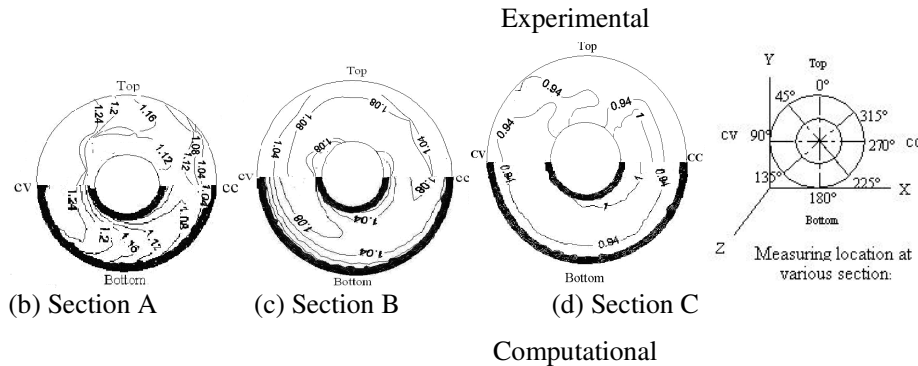

FIGURE 4. Comparison of normalized velocity distribution at Section A, Section B and Section C obtained through Computational and Experimental investigation

Figure 5 shows the comparison of performance parameters like coefficient of static pressure recovery and coefficient of total pressure loss obtained through experimental and computational investigation. From the figure it has been observed that coefficient of pressure recovery  $C_{pr}$  for the computational investigation was obtained as 31% compared to the experimental investigation, which obtained as 27%. Similarly the coefficient of pressure loss is obtained as 21% in computation investigation compared to the 17% of experimental study. This shows very good matching of the predicted results with the experimental one.

These agreements confirm that the CFD code using Standard k - ε model can predict the flow and performance characteristics reasonably well for similar geometries with same boundary conditions

### 3.4 Parametric investigation

To obtain a more insight of the performance parameters an intense parametric study of pressure recovery/loss coefficient for different area ratio diffusers with the angle turn 37.5°. For this purpose area ratios 1.15, 1.2, 1.25, 1.3, 1.35, 1.5, 1.75, 2, 2.25, 2.5, 2.8, 2.83, 2.85, 2.87, 2.9, 3, 3.15, 3.25, 3.5

and 3.75 with the angle of turns  $37.5^\circ$  annular curved diffusers have chosen. From this investigation it is observed from Fig. 5. that for the increase in area ratio from 1.15 to 2.25, static pressure recovery increases sharply after that increment in lesser gradient up to 2.86 and it was maximum at area ratio 2.86. But when area ratio increases from 2.86 to 3.75 pressure recovery decreases steadily. The coefficient of total pressure loss almost remains constant with the change in area ratio for similar inlet conditions.

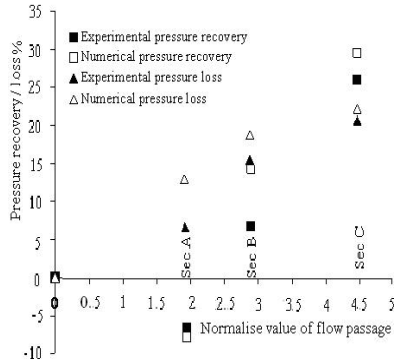

FIGURE 5. Comparison of Performance parameters obtained through computational and experimental investigation

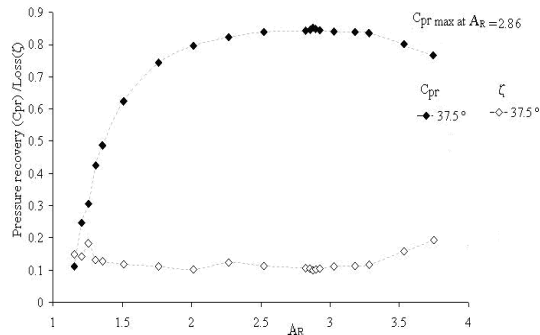

FIGURE 6. Variation of mass average pressure recovery and loss coefficients.

#### 4. CONCLUSION

Based on the present investigation following conclusion have drawn for the present paper. High velocity fluids shifted and accumulated at the concave wall of the exit section. A comparison between the experimental and predicted results for the annular curved diffuser show good qualitative agreement between the two. The coefficient of mass averaged static pressure recovery and total pressure loss are obtained as 31% and 21% in predicted results and in the experimental results their values obtained as 27% and 17% respectively, which indicate a good matching between the experimental and predicted results. From the parametric investigation it is observed that for the increase in area ratio from 1.15 to 2.25, static pressure recovery increases sharply after that increment in lesser gradient up to 2.86 and the maximum performance observed at area ratio 2.86. When area ratio increases from 2.86 to 3.75 pressure recovery decreases steadily. Among the different turbulence models within the fluent solver a standard k- $\epsilon$  model shows the good results and predicts the flow and performance characteristics well for annular curved diffusing ducts with uniform flow at inlet.

#### REFERENCE

- [1] Fox, R.W & Kline, S.J, (1962) "Flow Regimes in Curves Subsonic Diffuser", Trans ASME, Journal of Basic Engineering, Vol. 84, pp. 303 – 316.
- [2] Seddon, J, (1984) "Understanding and Countering the Swirl in S- ducts; Test on the Sensitivity of swirl to Fences", Aeronautical journal, pp.117-127.
- [3] Vakili, A .D. Wu, J.M. Liver P.& Bhat, M.K,(1984) "Experimental Investigation of Secondary Flow in a Diffusing S- Duct", University of Tennessee Space Inst, Report No. TRUTSI 86/14, University of Tennessee, Tullahoma, TN.
- [4] Yaras, M .I, (1996)"Effects of inlets conditions on the flow in a Fishtail Diffuser with strong Curvature", Trans ASME, Journal of Fluid Engineering, Vol. 118, pp. 772 – 778.
- [5] Reichert, B.A. & Wendt, B.J,( 1996) "Improving Curved Subsonic Diffuser Performance with Vortex Generator", AIAA Journal, Vol.14, pp. 65-72.
- [6] Majumdar, B., Singh, S.N., & Agrawal, D.P, (1997)"Flow Characteristics in S-shaped Diffusing Duct", Int Journal of Turbo and Heat Engines, Vol. 14, pp. 45 – 57.
- [7] Sonada, T. Arima, T. & Oana, M, (1998) "The influence of Downstream Passage on the Flow within an Annular S-shaped Ducts", Trans ASME, Journal of Turbo Machinery, Vol. 120, pp. 714 – 722.

- [8] Mullick, A. N. & Majumdar, B. (2006) "Experimental Investigation of flow Parameters in a Mild Curves S-shaped Diffusing Duct", Journal of Aerospace Science and Technologies, Vol. 58, No. 1, pp. 22 – 30.
- [9] Dominy, R.G. Kirkham, D.A. & A.D. Smith, (1998)"Flow Development through Inter turbine Diffuser", Trans ASME, Vol. 120, pp. 298 – 304.
- [10] Fuji, S. and Okiishi, T. H.(1997) "Curved Diffusing Annulus Turbulent Boundary-Layer Development", Authors' Report. No.ISU-ERI-Ames-71033, National Technical Information Service, Springfield, Va., 22151.as N72-10239.
- [11] Xia, J.L. Smith, B.I. Zierer, T. Schmidli, J. & G. Yadigaroglu, (1999) "Study of Turbulent flow Characteristics in a 180° bend Annular Diffuser with Blow off". Int comm. Heat Mass Transfer, Vol. 26, pp. 685 – 694.
- [12] Singh, S. N. Seshadri, V. K. Saha, Vempati, K.K., & Bharani, S, (2006) "Effect of inlet swirl on the performance of annular diffusers having the same equivalent cone angle", Proc. Inst.Mech.Engineer, Part G, Journal of Aerospace Engineering Vol. 220, No.2, pp.129-143.
- [13] Chowdhury, D, (2007) "Modelling and calibration of pressure probes", M.E Thesis, Jadavpur University.
- [14] Mukhopadhyay, S., Dutta, A. Mullick, A. N. & Majumdar, B, (2001) "Effect of Five-hole probe tip shape on its calibration", Journal of the Aeronautical Society of India, Vol. 53,No.4, pp.271-277.

#### **Authors Biographies**

**P. K. Sinha** received the B. Tech (Mechanical) and M.Tech. (Mechanical Designs of Machines) degrees both from N.I.T. Durgapur, India in 1984 & 1991 respectively. He is pursuing his Ph.D from Jadavpur University. His research interests are Experimental Fluid Dynamics and Aero dynamics, Machine Design and Non conventional Energy. He has published twenty papers. Presently he is working in Department of Mechanical Engineering, Durgapur Institute of Advanced Technology & Management, Durgapur. He is a Fellow of Institution of Engineers (India) and Life member of fluid Mechanics and Fluid Power.



**Dr. B. Majumdar** received the B.E. (Mechanical) and M.E. (Mechanical) degrees both from Jadavpur University, India in 1981 & 1983 respectively. He is obtained his Ph.D from Indian Institute of Technology, Delhi in 1995. His research interests are Experimental Fluid Dynamics and Aerodynamics, Hydro Power and wind power energy. He has published fifty eight papers. Presently he is working in Department of Power Engineering, Jadavpur University, Kolkata, India. He is a Life Member of Institution of Engineers (India).

